

**AN ROINN TALMHAÍOCHTA, BIA AGUS MARA**

**DEPARTMENT OF AGRICULTURE FOOD AND  
THE MARINE**

**S. 101**

**July 2016**

**MINIMUM SPECIFICATIONS FOR THE  
STRUCTURE OF AGRICULTURAL BUILDINGS**



**AN ROINN TALMHAÍOCHTA, BIA AGUS MARA**  
**DEPARTMENT OF AGRICULTURE, FOOD AND THE MARINE**  
**S.101: MINIMUM SPECIFICATIONS FOR THE STRUCTURE OF**  
**AGRICULTURAL BUILDINGS**

**The receiving of this specification does not imply approval of a grant application.** However, if written approval is issued, then this specification becomes part of the contract between the applicant and the Department of Agriculture, Food and the Marine.

This is a minimum specification. Where the word “SHALL” is used, then that standard (at least) must be followed in a grant-aided building. Where a procedure is “RECOMMENDED”, this is advice only on good practice.

For some structures, (haybarns, general sheds, etc.) no other specification is required, but for most buildings one of the Department Specifications shall be complied with in conjunction with this specification.

Copies of S101 and other relevant Department specifications are available on the department’s website at: [www.agriculture.gov.ie](http://www.agriculture.gov.ie) under Schemes and Specifications, ‘Farm Buildings’ (<http://www.agriculture.gov.ie/farmerschemespayments/farmbuildings/>) or by contacting the one of the local offices of the Department of Agriculture, Food and the marine.

This specification gives the full structural details of all of the recommended types of agricultural buildings. It is very strongly recommended that buildings are designed so that the structural options given here are used for all aspects of the building’s structure. **However, if other structural designs, higher eaves or greater spans are used, then a full set of design drawings and full structural calculations shall be prepared by a chartered engineer, and given to this Department for prior approval before the start of construction.**

References to Standards are to the current edition of the Irish, British or European Standard. Building frames are in general designed in accordance with the relevant Eurocode.

Note: All materials used in the construction of buildings to this specification shall be sourced as new. Second-hand materials are not permitted. Under no circumstances shall railway track be used in the construction of any building.

This specification is arranged as follows:

<b>A.</b>	<b>STRUCTURAL SPECIFICATION FOR INDIVIDUAL DESIGNS.....</b>	<b>8</b>
A.1	GENERAL BUILDING REQUIREMENTS.....	8
A.2	SIMPLE STEEL FRAME.....	9
A.3	LEAN-TO STRUCTURES .....	13
A.4	STEEL FRAME WITH STEEL TRUSS ROOF .....	14
A.5	STEEL PORTAL FRAME .....	19
A.6	TIMBER STRUCTURED DESIGN – GENERAL.....	22
A.7	TIMBER PORTAL FRAME .....	28
A.8	TRADITIONAL SOLID WALL AND TIMBER ROOF .....	28
A.9	CONCRETE FRAMED STRUCTURE.....	28
A.10	STEEL HOOPED STRUCTURE.....	29
<b>B.</b>	<b>GENERAL CLAUSES FOR ALL BUILDING TYPES.....</b>	<b>30</b>
B.1	EAVES HEIGHT & ROOF SLOPE .....	30
B.2	VENTILATION .....	30

**B.3 PROTECTION OF STEEL .....32**

**B.4 STANCHION ELIMINATION .....33**

**B.5 GRAFTING ONTO STANCHIONS .....34**

**B.6 CONCRETE SPECIFICATION .....34**

**B.7 CONCRETE FOUNDATIONS .....36**

**B.8 CONCRETE FLOORS .....37**

**B.9 MASS CONCRETE / BLOCKWORK WALLS.....37**

**B.10 ROOF CLADDING & SIDE CLADDING .....38**

**B.11 PURLINS, SIDE RAILS & FIXING OF CLADDING.....39**

**B.12 ROOF DRAINAGE .....40**

**B.13 ELECTRICAL INSTALLATIONS .....41**

**B.14 NATURAL LIGHTING .....41**

**B.15 DOORS .....42**

**B.16 CERTIFICATES.....42**

**SAFETY**

**APPLICANT’S RESPONSIBILITY FOR SAFETY**

Applicants are reminded that they have a duty under the Safety, Health, and Welfare at Work Act 2005 to provide a safe working environment on the farm, including farm buildings, for all people who may work on that farm. There is a further duty to ensure that any contractor, or person hired to do building work, provides and/or works in a safe environment during construction. It is the farmers responsibility to provide a construction stage project supervisor.

**SAFETY DURING CONSTRUCTION**

**Farmer/Applicant Responsibility:** Certain construction dangers may be encountered in the course of building or conversion work. Neither the Minister or any official of the Department will be in any way liable for any damage, loss or injury to persons, animals or property in the event of any occurrence related to the development and the applicant shall fully indemnify the Minister or any official of the Minister in relation to any such damage, loss or injury howsoever occurring during the development works.

**Dangers:** If any or all of the work is undertaken by the applicant/farmer he/she should seek competent advice and undertake all temporary work required to ensure the stability of excavations, superstructure, stanchion foundations and wall foundations, also to divert any drains, springs or surface water away from the works, and to guard against possible wind damage, or any other foreseeable risk. Additionally, a 150mm thick layer of hardcore should be placed around the site to provide a hard standing area for lifting equipment.

**Power lines:** Due to the complex criteria involved, where buildings are proposed within 35 metres of the centre of any overhead power line, the landowner shall contact ESB Networks in advance to ascertain the specific minimum building clearance requirement. It is a requirement on landowners under The Electricity Supply Acts to notify ESB Networks, at least, two months before commencement of any construction works near overhead lines. As a guide, Table 1 below set out the usual minimum clearance distances required, however, ESB Networks shall be contacted and their advice followed for any structure within 35m of the centre line of an overhead power line. ESB will provide landowners with written confirmation of the required clearances. Landowners can contact ESB through phone numbers provided on their electricity bills.

Where building work is undertaken near power lines there is also a safety issue regarding Machinery, Tipper Trucks and Elevators operating without proper safety measures in place. When landowners contact ESB they will be provided with relevant safety literature.

**Table 1: In general the following clearances apply to various voltage levels.**

Voltage	Clearance
Low Voltage	0.5 to 3 Metres
Medium Voltage	3 to 6 Metres
38KV Lines	10 to 17 Metres
110kv Lines	23 Metres
220KV Lines	30 Metres
400KV Lines	35 Metres

**Note:**

- ESB overhead lines consist of lines at various voltage levels and require specific safety clearances from buildings depending on voltage level and construction type.
- Clearances are specific to the line voltage, building height, location in line span and ground levels.

**Danger to children:** It is the applicant’s responsibility to prevent children from playing or spending time in the vicinity of any building work.

**Roof work:** When working on any roof, it is essential to assume that the roof is fragile, unless confirmed otherwise by a competent person.

The HSA Code of Practice for Safety in Roofwork shall be consulted prior to any work being undertaken on a roof. All advice in the code of practice shall be followed.

The HSA code of practice gives recommendations and practical guidance on how to work safely on roofs, including the safe maintenance of roof mounted plant and services, and how to design and plan for safe working. It offers guidance on the design and construction of roofs on new buildings and the maintenance, cleaning and demolition of existing roofs. All work at height poses a risk and a risk assessment should be carried out to assess those risks and put appropriate controls in place.

It is strongly recommended that all agricultural roofs have a safety sign warning that the roof is fragile. While roofs are non-fragile when installed, they may become fragile over the lifetime of the roof. Figure 1 shows an example of a typical fragile roof warning sign.



**Figure 1:** Typical fragile roof warning sign.

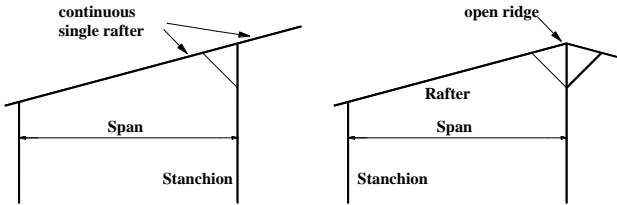
## **MAINTENANCE**

All farm buildings require regular maintenance to ensure the health and safety of personnel and animals. After each winter-season buildings should be thoroughly washed and cleaned out. Fittings such as slats, electrical fittings, drinking arrangements, etc., should be periodically checked, and all defective items replaced. Include reference to design to enable safe maintenance.

**STRUCTURE TERMINOLOGY**

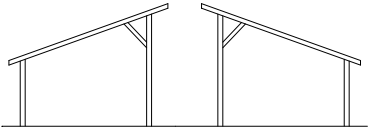
**Bay Width:** The bay width is the distance from the centre of a stanchion of a bay frame to the centre of the corresponding stanchion of the adjacent bay frame. **Agricultural buildings in Ireland are designed to two standard bay widths of 4.8m and 6.4m. It is very strongly recommended that these bay widths are used in all designs, and that any adjustments to the floor area are made by changing the span.** Buildings with alternative bay widths shall conform to the specifications of that standard bay width which is higher than the particular bay width in question, e.g.: a bay width of 5.0m shall comply with the specification for the 6.4m bay width. Alternative bay widths are therefore uneconomic.

**Span:** A span refers to the distance or dimension between two free-standing stanchions comprising a single bay frame of a steel frame building as illustrated in Figure 2. The distance measured is from the inside flange of one stanchion to the inside flange of the other.

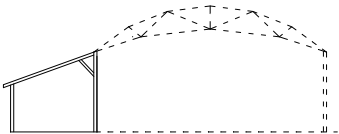


**Figure 2** Definition/Interpretation of span

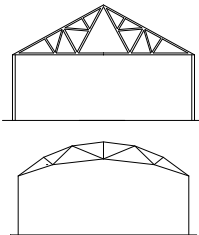
**Simple Steel Frame – A2.** This consists of a framework of steel stanchions, rafters, and bracing. It is used for most animal houses with feeding passages, and also for sloped-roof ‘single-sided’ houses. It can easily accommodate feed barriers, pens, and facilitate good ventilation, and is therefore strongly recommended for slatted or scraped floor houses for cattle, cows or sheep.



**Lean-To Structure – A3.** This consists normally of a framework supported by two rows of steel stanchions, of which one row is part of an existing building. Where it exists independently of other structures, it resembles a simple steel frame. Lean-tos are often constructed to increase cubicle accommodation or loose-housing.

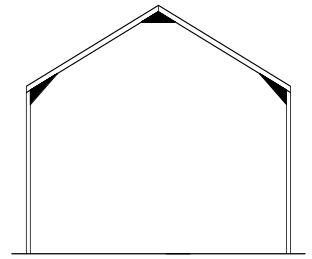


**Steel Frame with Steel Truss Roof – A4.** This is used for unrestricted internal space, as well as for wide-span lean-to buildings. It is appropriate for hay or for other produce storage, and for general-purpose sheds. However, steel trusses require a high standard of protection and on-going maintenance in the aggressive environment of livestock housing, and are, therefore, not recommended for this use. The layout and the lack of internal supports make the provision of pens etc., more expensive.

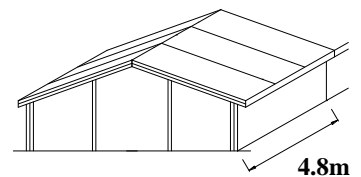


**Steel Portal Frame – A5.** This is a single-span frame of stanchions and rafters, strengthened with knee and apex braces, and by beams and bracing between the frames. It is used for any house for a wide unrestricted span, or for maximum flexibility of use.

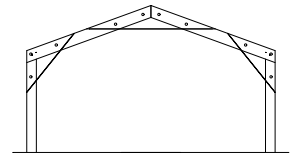
Portal frames (Steel, Timber, Concrete) are an expensive form of construction, and when used for bovine housing the layout does not facilitate barriers, pens etc. and their installation involves further expense. Outlet ventilation can be difficult to achieve. The layout and the lack of internal supports make the provision of pens etc., more expensive.



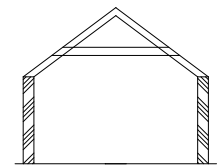
**Simple Timber Frame – A6.** This frame uses timber columns, rafters and bracing. Timber sections may be whole, or formed from smaller sections using nails or bolts, or by lamination with special glues. All timber structural sections in farm buildings must be pressure treated with an approved preservative to prevent premature decay.



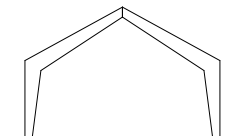
**Timber Portal Frame – A7.** This frame normally requires deep composite timber stanchions with knee and apex bracing, and deep composite rafters. These sections are usually formed either from plywood with added sawn timber sections, or from laminated glued units. Steel stanchions and knee braces may also be combined with timber composite rafters and apex braces.



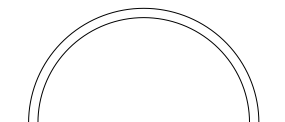
**Traditional Solid Wall with Timber Roof – A8.** This system may be used for buildings with spans less than 6.75m. It is appropriate for dairies, cow byres, and small milking parlours, as well as for calf and other small animal houses.



**Concrete Framed Structure – A9.** A combined stanchion and rafter is formed in reinforced concrete, and erected to become part of a portal frame structure, or used in a lean-to shed. These specialist buildings must be manufactured, constructed and erected by specialist firms. Full certification of both design and manufacture is required.



**Steel Hooped Structure – A10.** This consists of a series of curved steel frames, roofed with a simple, or insulated, plastic membrane. It is appropriate for mushroom and other horticultural buildings, and for low-cost and short-life housing for sheep and other animals. It is normally designed, supplied and erected by specialist companies who shall ensure it meets recognised standards (e.g. European Standards).



## **A. STRUCTURAL SPECIFICATION FOR INDIVIDUAL DESIGNS**

### **A.1 GENERAL BUILDING REQUIREMENTS**

#### **A.1.1 Building Certification**

Where steel frame work is manufactured by a contractor it needs to be CE Marked and have a Declaration of Performance. All steel frame structures shall be CE marked and produced in a plant certified by a Notified body (e.g. NSAI or equivalent), to manufacture structural steel frames in accordance with IS EN 1090. A Declaration of Performance shall be supplied for each building, by the certified steel frame manufacturer. The contractor must be certified to EN 1090-1, even in cases where the steel frame is manufactured on site. The building contractor shall be certified to, at least, execution class 1 under IS EN 1090.

Where the building is being grant-aided, and the applicant manufactures the steel frame themselves, then the applicant shall submit up-to-date certificates of welding competence in accordance with EN ISO 9606-1:2013. The certificate shall cover both butt welds and fillet welds in the flat and horizontal positions.

Where there is either no Declaration of Performance, or welding certificates the building will be considered NOT to be in compliance with this specification.

#### **A.1.2 Buildings outside of S.101**

Where it is desired to construct a building with an eave height greater than that specified in the relevant section or with a roof slope outside the specified range or where the span is greater than specified, then a full set of design drawings (including details of steel sizes and joint details) and full structural calculations for the entire building shall be prepared by a Chartered Engineer, and given to this Department for prior approval before the start of construction. The design of the building shall be in accordance with IS EN 1993: Eurocode 3: Design of steel structures and any other relevant Eurocode. Loadings shall be to IS EN 1991, concrete structure shall be to IS EN 1992, composite structure shall be in accordance with IS EN 1994, timber structures shall be to IS EN 1995 and masonry structures shall be to IS EN 1996.

#### **A.1.3 Material requirements**

All steel shall be supplied with CE Marking and shall be, at least, steel grade S275 to be supplied with a CEV less than 0.40.

All steel sections, plates and flats shall meet the quality requirements of EN 10025-2 and all hollow sections shall meet the quality requirements of EN 10210-1/10219-1.

The surface condition of plates and flats shall meet class A2 of EN 10163-2 and the surface condition of sections shall meet class C1 of EN 10163-3.

All material inspection certificates shall be type 3.1 to EN 10204. All material inspection certificates shall be issued with (or prior to) steel. Cast references shall be marked on all steel.

All bolts used in the manufacture of steel frames shall be at least grade 8.8 and certified in accordance with EN15048-1:2007 and be marked SB.

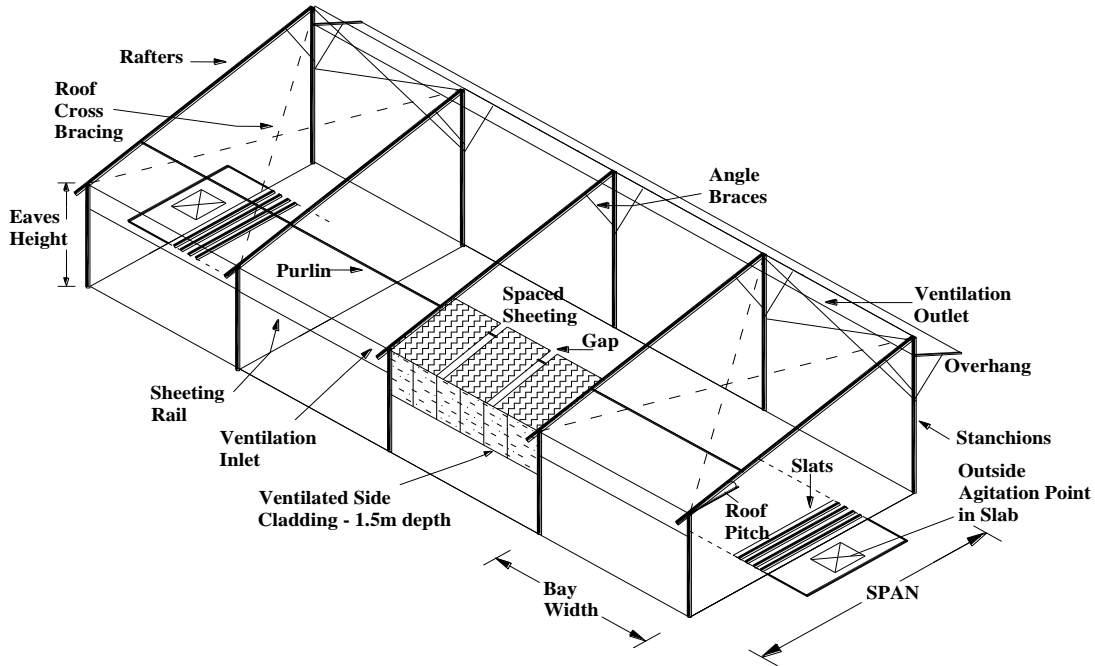
Where a component of a building is covered by a Harmonised Standard, then only products that are produced and certified in accordance with the relevant standard are permitted.



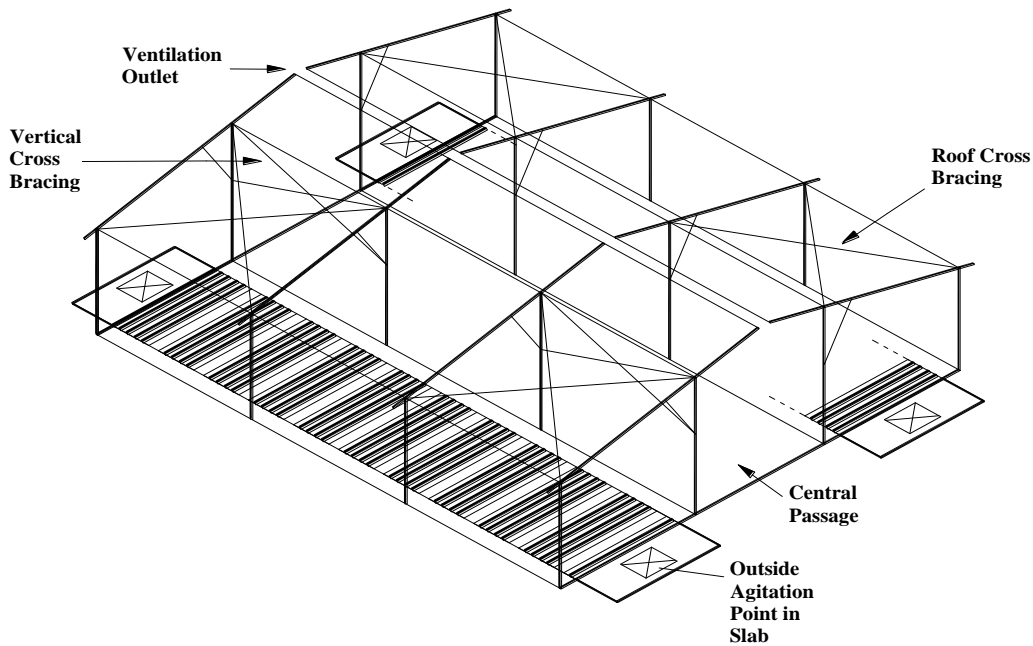
### A.2 SIMPLE STEEL FRAME

This specification covers simple steel frame buildings with a maximum eave height of 5.0m and a roof slope in the range 12° – 15°. Any simple steel frame building with an eave height greater than 5.0 m or with a roof slope outside the specified range will require a full design to be undertaken by a Chartered Engineer as required by clause A.1. The building shall be designed in full accordance with IS EN 1993.

The following illustrations are examples of typical simple steel frame houses:



**Figure 3** Single-sided simple steel frame house (4 bay)



**Figure 4** Double-sided simple steel frame house (3 bay/4.8m per bay/14.4m/tank-16.8m)

### A.2.1 Stanchion sizes

Stanchions shall be placed up to 4.8m centres where timber purlins are used, and up to 6.4m centres for cold-formed special steel purlins. Stanchions shall be sized as per Table 2 or Table 3.

### A.2.2 Rafter sizes

Rafters shall be formed from steel beams. Rafters shall be sized as per Table 2 or Table 3.

**Table 2 Stanchion and rafter sizes: IPE sizes**

Span up to	Bay Width	European Standard Section (mm)		
		Stanchion		Rafter
		Up to 4.0m eave	Up to 5.0m eave	
7.6m	4.8m	IPE 200	IPE 220	IPE 200
	6.4m			
9.15m	4.8m	IPE 220	IPE 240	IPE 220
	6.4m	IPE 240		IPE 240
12.2m	4.8m	IPE 270	IPE 270	IPE 270
	6.4m	IPE 300		

**Table 3 Stanchion and rafter sizes: UB sizes**

Span up to	Bay Width	British Standard Section (mm)		
		Stanchion		Rafter
		Up to 4.0m eave	Up to 5.0m eave	
7.6m	4.8m	203 x 102 x 23 kg/m	203 x 133 x 25 kg/m	203 x 102 x 23 kg/m
	6.4m			
9.15m	4.8m	203 x 133 x 25 kg/m	203 x 133 x 25 kg/m	203 x 133 x 25 kg/m
	6.4m	254 x 146 x 31 kg/m	254 x 146 x 31 kg/m	203 x 133 x 30 kg/m
12.2m	4.8m	254 x 146 x 37 kg/m	254 x 146 x 37 kg/m	254 x 146 x 31 kg/m
	6.4m	305 x 127 x 48 kg/m	305 x 127 x 48 kg/m	

**Notes:**

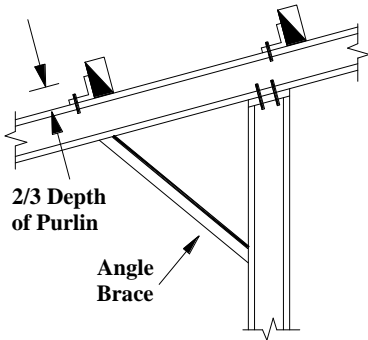
- Table 2 and Table 3 are based on simple steel frames with a maximum eaves height of 5.0m, a roof slope of 15° and vertical cross bracing to high level stanchion at a height of 4m, when the stanchion itself is higher than 6m.
- In bay widths up to 4.8 metres, timber rafters, 300mm x 75mm may be used to a maximum span of 4.6 metres [4.3m under fibre-cement sheets]. This also applies to lean-to structures.
- The above tables are suitable only for a maximum of three lines of stanchions between the eave and apex of a building (Figure 4 shows two lines of stanchions). Where there are more than three lines of stanchions on either side of the apex of a building clause A.1.2 applies. The third line of stanchions shall always be sized as for a 5.0m eave, even if the eave is less than 4.0m.

### A.2.3 Stanchion tops.

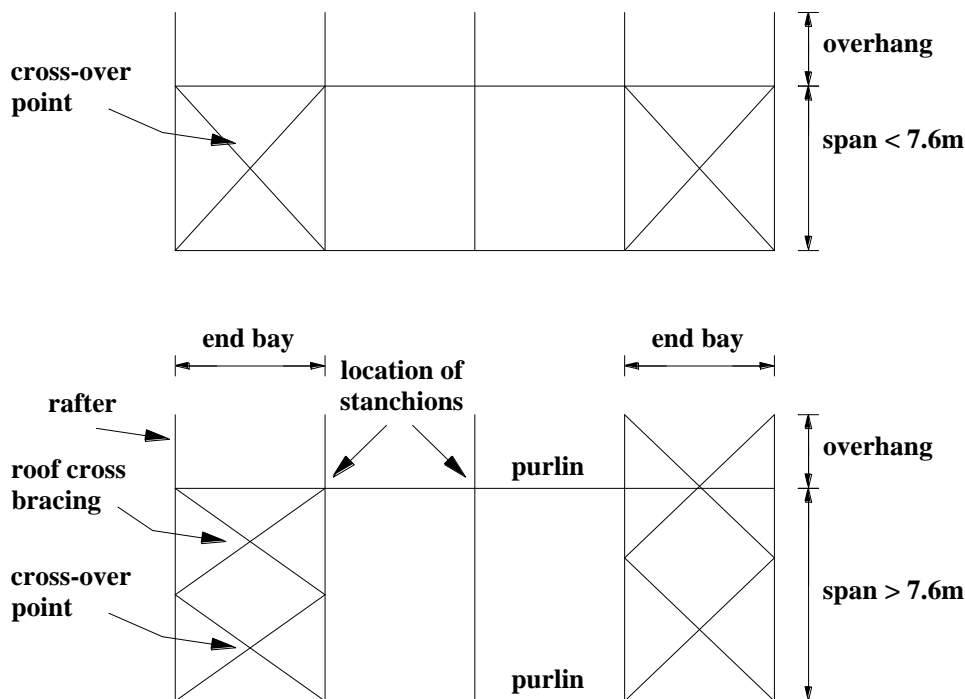
Stanchion tops shall be beveled at the chosen angle of roof slope and suitable cap plates welded to stanchion tops. Rafters shall be securely fixed to the cap plates using two number 16mm bolts per connection. Where the rafter is connected to the side of the stanchion, a plate welded to the rafter end shall be connected to the stanchion using 4 No. 16mm bolts.

**A.2.4 Angle bracing in simple steel frames.**

For all spans the rafter shall be braced from the high level stanchion, across the acute angle, by 60 x 60 x 6mm angle iron, at least 1.5m long and secured by one 16mm bolt at each end (Figure 5). For spans of 7.6m or greater the brace shall consist of two such angles 1.5m long, back to back and spot welded at 500mm centres, and secured by two number 16mm bolts at each junction. For spans greater than 9.15m, angle braces shall be at least 2.0m in length. Where mass concrete walls at least 1.8m high are present in the gable frame, then the angle brace for gable frames may be omitted.



**Figure 5 Bracing**



**Figure 6 Plan view of single-sided house**

**A.2.5 Roof cross bracing in simple steel frames.**

Cross bracing to both end bays shall be provided in the plane of the roof of all houses with four or more bays. For a three bay house, cross bracing may be installed in the centre bay instead of both end bays. In a two bay house cross bracing is required in one bay only. For roof spans of 7.6m or greater, a second set of braces shall be installed in each bay (Figure 6). For bays widths up to 6.0m roof-cross bracing shall consist of 50 x 50 x 6mm angles secured to the rafters by 16mm bolts, and similarly fastened to each other at the cross-over point. For bay widths of 6.0m and above roof-cross bracing shall consist of 70 x 70 x 6mm angles secured to the rafters by 16mm bolts, and

similarly fastened to each other at the cross-over point or 88.9mm x 3.2mm CHS in a “Z” or “<” pattern.

In addition, where buildings are 32m or longer, roof cross bracing shall be installed in internal bays. With 6.4m bays, bracing shall be installed in every second bay; with 4.8m bays, bracing shall be installed in every third bay.

### A.2.6 Vertical cross bracing in simple steel frames.

Where stanchions at the central passage are higher than 6m, then vertical cross-bracing shall be provided in all end bays at a height of 4m going up to the top of the stanchion or 4m whichever is lower. For bays widths up to 6.0m this shall consist of 50 x 50 x 6mm angles secured to the web of stanchions with 16mm bolts, and similarly fastened to each other at the crossover point. For bay widths of 6.0m and above vertical-cross bracing shall consist of 70 x 70 x 6mm angles secured to the rafters by 16mm bolts, and similarly fastened to each other at the cross-over point.

In addition, where buildings are 32m or longer, the vertical cross bracing shall be installed in internal bays. With 6.4m bays, the internal bracing shall be installed in every second bay; with 4.8m bays, bracing shall be installed in every third bay.

### A.2.7 Overhangs

Overhangs shall not exceed a horizontal distance of 2.5m shall be one of the designs shown in Figure 7. Where the overhang is supported independently of the main roof, the overhang rafter and supporting member shall be at least an IPE 180. The rafters shall be secured to the stanchion using four No. 16mm bolts. Alternatively, a truss may be used constructed of members specified for a lean-to truss (span up to 6.7m with a minimum of two triangulations). A canopy of up to 2.5m at the back of the shed is permitted. This aids in preventing entry of rain.

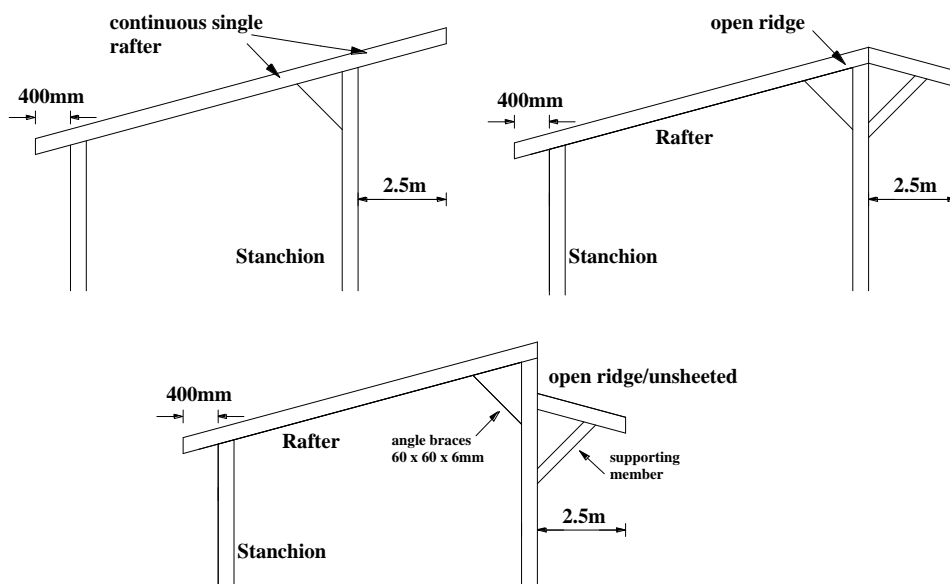
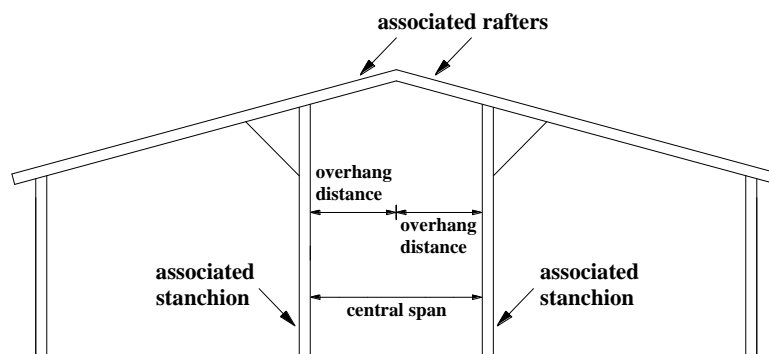


Figure 7 Interpretation of overhang options

### A.2.8 Central spans in steel framed structures.

The central span is a span in which two overhangs are connected at the apex. The stanchions and rafters are sized in accordance with a simple steel frame (A2), a portal frame (A5) or a combination of both (Figure 8). These conditions are as follows:

- Where both overhangs are 3.5m or less, simple steel frame (A2) specification shall apply.
- Where one or both overhangs is greater than 3.5m and both less than 4.0m, simple steel frame (A2) detail shall apply, but knee and apex braces as in steel portal frames (A5) shall be incorporated.
- Where one or both overhangs is greater than 4.0m, then the associated stanchions and rafters shall comply with specifications for steel portal frames (A5).



**Figure 8**                      **Double-sided house with central span**

### A.3 LEAN-TO STRUCTURES

Design Note: Where it is proposed to erect a lean-to, the following points shall be adhered to:

- The minimum eaves height of the lean-to shall be 3m and the minimum roof slope shall be 12°.
- Where the lean-to is for animal housing the design shall incorporate full inlet and outlet ventilation (see clause B2). Where outlet ventilation is in anyway restricted or where a lean-to is constructed against an existing shed, a spaced sheet roof shall be installed in the lean-to (Clause B2, B11.7 – spaced roof sheeting).
- Where a lean-to is constructed as a simple steel frame, section A2 shall apply.
- Where a truss roof is proposed, section A5 shall apply.
- The stanchion of the existing building to which the lean-to is being connected shall be of sufficient size for both the existing building and the lean-to, and show signs of only minimal corrosion. If neither condition is met then a new stanchion shall be installed.
- Rafters shall be secured to existing stanchions as per A2.3.

## **A.4 STEEL FRAME WITH STEEL TRUSS ROOF**

### **A.4.1 Stanchions**

Stanchions shall be centred either at 4.8m or 6.4m apart. The top of each stanchion shall incorporate a proper bearing plate for trusses or rafters.

This specification covers steel truss roof buildings with a maximum eave height of 5m and a roof slope in the range 12° – 15°. Any steel truss roof building with an eave height greater than 5 m or with a roof slope outside the specified range will require a full design to be undertaken by a Chartered Engineer as specified in section A.1.

**Table 4 Stanchion sizes for truss roofs [eaves height: up to 5m]**

<b>Span up to</b>	<b>Bay Width</b>	<b>European Section (mm)</b>	<b>British Section (mm)</b>
7.6m	4.8m 6.4m	IPE 200	203 x 102 x 23kg/m
9.15m	4.8m 6.4m	IPE 220	203 x 133 x 25kg/m
12.2m	4.8m 6.4m	IPE 240	254 x 146 x 31kg/m
15.2m	4.8m 6.4m	IPE 270	254 x 146 x 37kg/m

### **A.4.2 Truss Construction.**

Trusses shall be fabricated using shot blasted steel, as per clause B3. Triangulation patterns should relate to the number of purlins to be carried and purlin cleats should be located as closely as possible to node-points i.e. where different members come together. Members of triangulated trusses shall not be less than the dimensions shown in the tables 5, 6, 7, and 8 below, which apply to lean-tos, bow trusses, A roofs and round roofs respectively. Where struts are longer than 1.8m they shall be at least 60 x 60 x 6mm unless otherwise stated. Truss designs that are different from those outlined in this specification shall be submitted by the Applicant/Planner to the Department for prior acceptance.

### **A.4.3 Truss/Stanchion connections.**

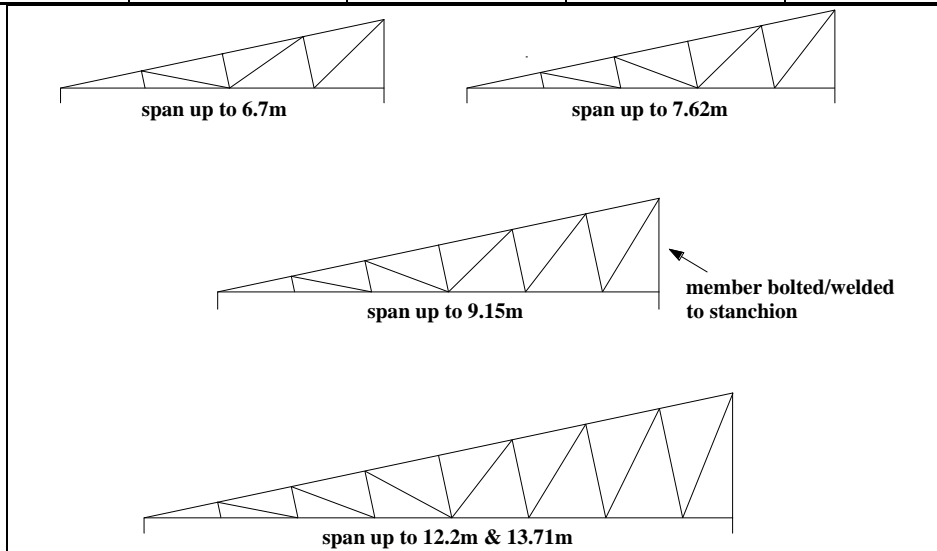
Where a truss is hung from as opposed to resting on the support stanchion it shall rest on a supporting angle iron cleat welded or bolted to the stanchion, and the top and bottom truss members shall be secured to the stanchion using 2 No. 16mm bolts to each member. In the case of a bow truss the connection plate shall be secured by 4 No. 16mm bolts and the plate must bear flush against the stanchion. Bolts and nuts shall be standard zinc plated bolts of grade 4.6 minimum. Where truss is resting on stanchion the truss shall be secured by at least 2 No 16mm bolts.

### **A.4.1 Gable stays for truss roof.**

Gable (wind) stays, 50 x 50 x 6mm steel angle shall extend from the bottom member of end trusses at 45° approx. to a matching purlin. Gable stays greater than 1.8m long shall be 60 x 60 x 6mm steel angle. Two such stays shall be used, located symmetrically about the mid-span on all spans up to 12.2m. Over 12.2m, 4 such stays (evenly spaced) shall be required.

**Table 5 Lean-to roof truss member sizes (mm)**

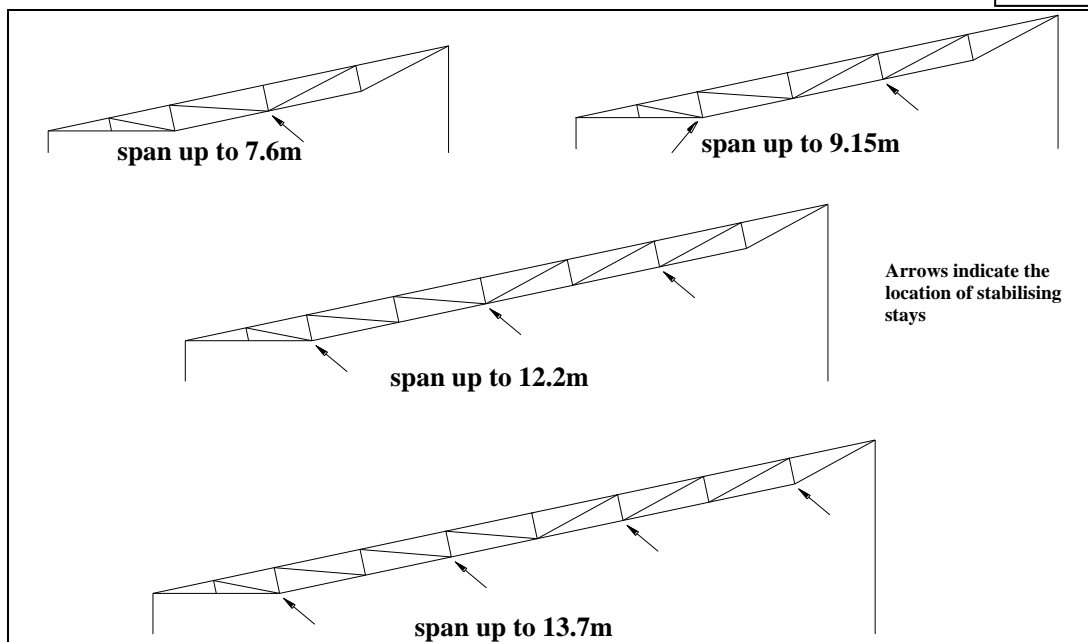
Span up to (m)	Bay Width (m)	Top Truss Member	Bottom Truss Member	Internal Members
6.7	4.8	70 x 70 x 8	50 x 50 x 6	50 x 50 x 6
	6.4	80 x 80 x 8	60 x 60 x 6	60 x 60 x 6
7.6	4.8	80 x 80 x 8	60 x 60 x 6	60 x 60 x 6
	6.4	90 x 90 x 8	60 x 60 x 6	60 x 60 x 6
9.15	4.8	90 x 90 x 8	60 x 60 x 6	60 x 60 x 6
	6.4	100 x 100 x 8	90 x 90 x 8	60 x 60 x 6
12.2	4.8	100 x 100 x10	90 x 90 x 8	70 x 70 x 6
	6.4	100 x 100 x12	90 x 90 x 8	70 x 70 x 6
13.7	4.8	100 x 100 x12	90 x 90 x 8	70 x 70 x 6
	6.4	100 x 100 x15	90 x 90 x 8	80 x 80 x 6



**Figure 9 Triangulation detail for lean-to roof trusses**

**Table 6 Bow truss member sizes (mm)**

Span up to (m)	Bay Width (m)	Top Truss Member	Bottom Truss Member	Internal Members
7.6	4.8	70 x 70 x 8	60 x 60 x 6	50 x 50 x 6
	6.4	90 x 90 x 8	70 x 70 x 6	50 x 50 x 6
9.15	4.8	90 x 90 x 8	70 x 70 x 6	50 x 50 x 6
	6.4	90 x 90 x 10	70 x 70 x 8	50 x 50 x 6
12.2	4.8	100 x 100 x10	70 x 70 x 8	60 x 60 x 6
	6.4	100 x 100 x15	90 x 90 x 8	70 x 70 x 6
13.7	4.8	100 x 100 x15	90 x 90 x 8	70 x 70 x 6
	6.4	100 x 100 x15	100 x 100 x10	90 x 90 x 8



**Figure 10 Bow truss details (truss depth = 500mm)**

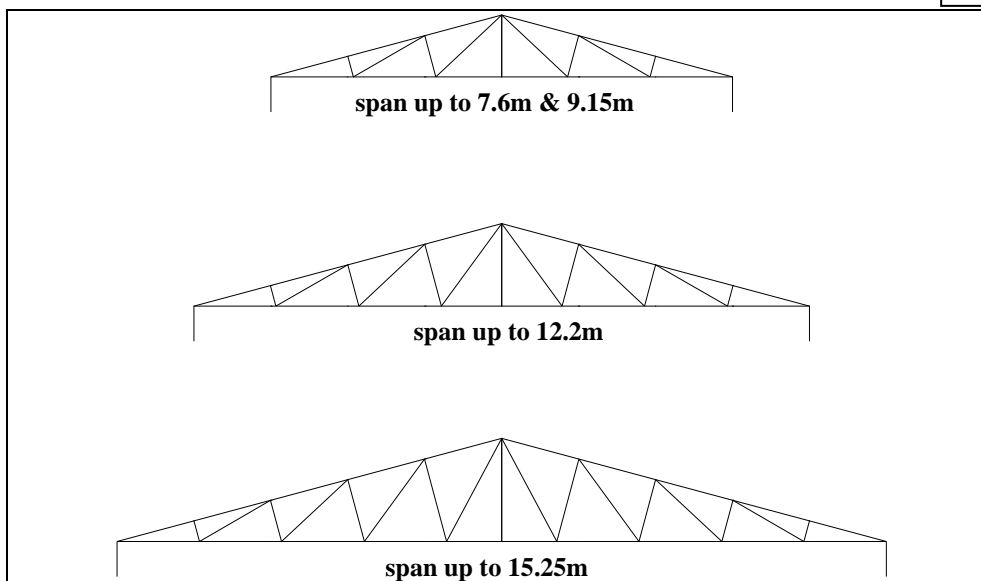
**A.4.2 Stabilising stays for a bow truss roof.**

Bow trusses shall be stabilised by the use of a pair of stays, connected to the bottom member at or near it's mid-point and carried up to corresponding purlins, for spans up to 7.6m. On spans up to 9.15m, two sets of stays shall be used at equidistant locations along the truss. On spans up to 12.2m, three sets of stays shall be used and four sets for spans up to 13.7m. Stays shall be 50 x 50 x 6mm steel angle. Bolted connections to timber shall incorporate toothed washers - single or dual faced as appropriate. Braces and stays shall be fastened by 16mm black bolts.

**Table 7 A-Truss member sizes (mm)**

Span up to (m)	Bay Width (m)	Top Truss Member	Bottom Truss Member	Internal Members
7.6	4.8	70 x 70 x 6	50 x 50 x 6	50 x 50 x 6
	6.4	70 x 70 x 8	50 x 50 x 6	50 x 50 x 6
9.15	4.8	70 x 70 x 8	50 x 50 x 6	50 x 50 x 6
	6.4	80 x 80 x 8	60 x 60 x 6	50 x 50 x 6
12.2	4.8	90 x 90 x 8	60 x 60 x 6	50 x 50 x 6
	6.4	90 x 90 x 10	60 x 60 x 8	60 x 60 x 6
15.2	4.8	100 x 100 x 8	90 x 90 x 8	60 x 60 x 6
	6.4	100 x 100 x 10	90 x 90 x 8	70 x 70 x 6





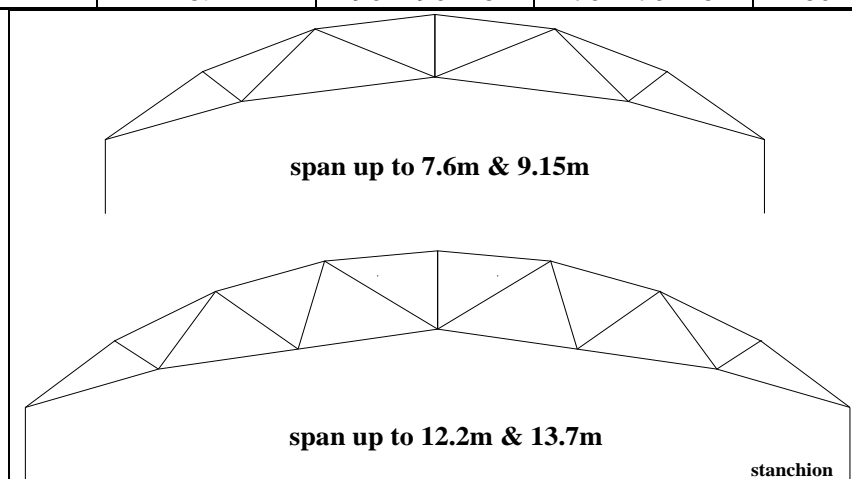
**Figure 11 A-Roof trusses**

**A.4.3 Eaves bracing for truss roof of haybarns.**

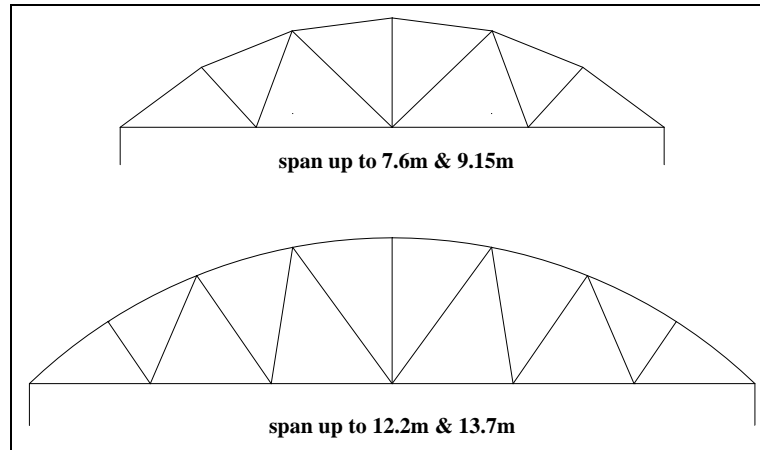
Suitable steel angle bracing not less than 50 x 50 x 6mm shall be provided on all haybarns. Each brace shall be fixed to the underside of the timber eaves beam (wall plate) a distance of 1.2m from stanchion and fixed to stanchion at a point 1.2m from the top. Where side cladding is provided from the wall-plate down, for a minimum depth of 1.4m, the above bracing is optional.

**Table 8 Haybarn roof truss member sizes (mm)**

Span up to (m)	Bay Width (m)	Top Truss Member	Bottom Truss Member	Internal Members
7.6	4.8	60 x 60 x 6	50 x 50 x 6	50 x 50 x 6
	6.4	60 x 60 x 8	50 x 50 x 6	50 x 50 x 6
9.15	4.8	70 x 70 x 8	50 x 50 x 6	50 x 50 x 6
	6.4	70 x 70 x 10	50 x 50 x 6	50 x 50 x 6
12.2	4.8	70 x 70 x 8	60 x 60 x 6	60 x 60 x 6
	6.4	80 x 80 x 8	60 x 60 x 6	60 x 60 x 6
13.7	4.8	80 x 80 x 8	70 x 70 x 6	60 x 60 x 6
	6.4	90 x 90 x 8	70 x 70 x 6	60 x 60 x 6



**Figure 12 Triangulation detail for gathered (haybarn) roof truss**

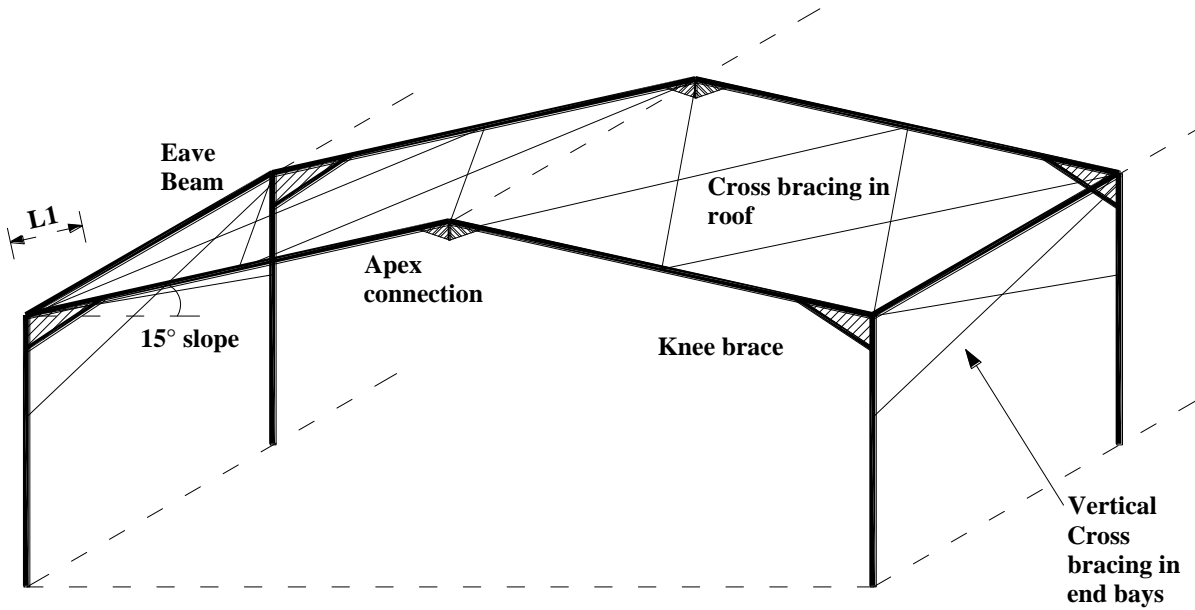


**Figure 13**      **Triangulation detail for haybarn roof end truss**

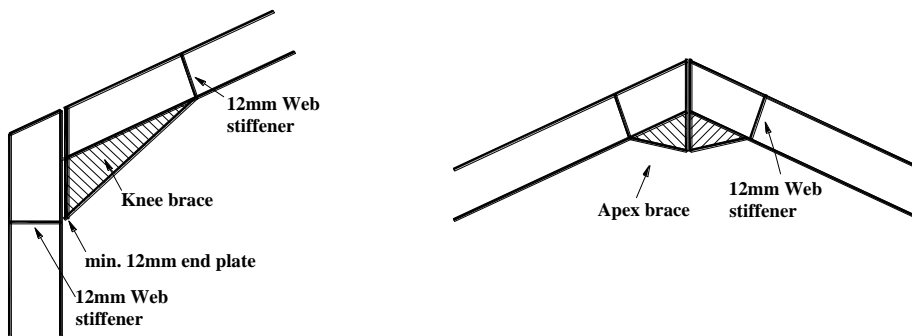
**A.5 STEEL PORTAL FRAME**

This specification covers steel portal frame buildings with a maximum eave height of 5m and a roof slope in the range 12° – 15°. Any steel portal frame building with an eave height greater than 5 m or with a roof slope outside the specified range will require a full design to be undertaken by a Chartered Engineer as required by clause A.1.

[eaves height: up to 5m;      slope: 15° (12° – see clause B1.2)]



**Figure 14                      Elements in portal frame**



**Figure 15      a) Knee haunch details**

**b) Apex haunch details**

### A.5.1 Stanchion and rafter sizes

Stanchions and Rafters shall be sized as follows:-

**Table 9 Stanchions and rafters for portal frames in IPE sections**

Span up to:- m	Bay widths m	Stanchions IPE Sections (mm)	Rafters IPE Section (mm)	Knee haunch Length (mm)	No. of Bolts	
					Knee Joint	Apex Joint
9.15	4.8	IPE 220	IPE 200	910	6	4
	6.4					
12.2	4.8	IPE 240	IPE 220	1220	8	4
	6.4					
15.2	4.8	IPE 300	IPE 270	1500	8	6
	6.4					
18.3	4.8	IPE 360	IPE 330	1830	10	6
	6.4					
21.35	4.8	IPE 400	IPE 360	2130	10	6
	6.4					
24.4	4.8	IPE 450	IPE 450	2440	12	8
	6.4					

**Table 10 Stanchions and rafters for portal frames in BS (British Standard) sections**

Span up to:- m	Bay widths m	Stanchions British Section UB (mm)	Rafters British Section UB (mm)	Knee haunch Length (mm)	No. of Bolts	
					Knee Joint	Apex Joint
9.15	4.8	203x133x25kg/m	203x102x23kg/m 203x133x25kg/m	910	6	4
	6.4					
12.2	4.8	254x146x31kg/m	203x133x25kg/m 254x146x31kg/m	1220	8	4
	6.4					
15.2	4.8	305x165x40kg/m	305x102x33kg/m 305x165x40kg/m	1500	8	6
	6.4					
18.3	4.8	356x171x51kg/m	356x171x45kg/m 356x171x51kg/m	1830	10	6
	6.4					
21.35	4.8	406x178x60kg/m	356x171x51kg/m 406x178x60kg/m	2130	10	6
	6.4					
24.4	4.8	457x191x67kg/m	457x191x67kg/m 457x191x67kg/m	2440	12	8
	6.4					

### A.5.2 Eaves Beams.

Steel eave beams shall be provided to all portal frames, except where solid mass/reinforced concrete walls **in all bays on both sides of the frame**, are carried up from ground level to at least two thirds of stanchion height. (**Note:** Where eaves beams are being omitted, care should be taken to provide temporary support to frames during construction).

For bay width up to 4.8m eaves beams shall be UB 127 x 76 x 13kg/m or IPE 140. For bay width up to 6.4m eaves beams shall be UB 152 x 89 x 16kg/m or IPE 180. Eaves beams to be fitted with 12mm end plates and bolted to the web of stanchion with 4 No 20mm bolts at each end.

### A.5.3 Knee Haunches.

Knee Haunches shall be cut out of the same section as the rafters, to lengths as shown in Table 9 and Table 10. Haunches shall be welded to rafter flange with double fillet weld for full length of haunches; end plates shall be welded to stanchion end of rafter/haunch combination, and sized according to Table 11. Rafter/haunch to be fixed to stanchion with 20mm (8.8 grade) bolts evenly spaced, using the number shown in Table 9 and Table 10. Web stiffeners of 12mm steel plate shall be inserted into the stanchion at bottom of haunch and a similar stiffener into the rafter, at top end of haunch.

### A.5.4 Apex Haunches

Apex Haunches shall be cut out of same section as the rafters. Haunches shall be welded to rafter flange with double fillet weld for full length of haunch; end plates (Table 11) shall be welded to end of each rafter/haunch connection with a double fillet weld for full depth of rafter/haunch combination. Connection plates to be jointed with 20 mm bolts (8.8 grade) evenly spaced, using the number shown in Table 9 and Table 10.

**Table 11 End plate thickness for rafter connections**

Span up to:-(m)	End Plate Thickness (mm)
9.15	10
12.2	10
15.2	12
18.3	15
21.35	20
24.4	25

### A.5.5 Gable Frames

Stanchions (152 x 152 x 23.4kg/m UC or equivalent section) shall be installed in gable frames from foundation level to rafter at a maximum spacing of 5m.

### A.5.6 Roof Cross bracing in portal frames.

Cross bracing to both end bays shall be provided in the plane of the roof of all portal frames (2 No. X-braces per end). For bays widths up to 6.0m roof cross bracing shall consist of 60 x 60 x 6mm angles secured to the rafters by 16mm bolts, and similarly fastened to each other at the cross-over point. For bay widths of 6.0m and above roof-cross bracing shall consist of 70 x 70 x 6mm angles secured to the rafters by 16mm bolts, and similarly fastened to each other at the cross-over point or 88.9mm x 3.2mm CHS in a “Z” or “<” pattern. For spans of 15.2m or greater, a second set of braces shall be installed in each end bay in the plane of the roof as shown in Figure 14.

In portal frame buildings 32m or longer, roof cross bracing and vertical cross bracing shall be installed in internal bays. With 6.4m bays, bracing shall be installed in every second bay; with 4.8m bays, bracing shall be installed in every third bay.

### A.5.7 Vertical cross bracing in portal frames

Vertical cross bracing of at least 60 x 60 x 6mm angle shall be fixed to each end span, if built-in concrete walls do not extend to at least two thirds of stanchion height. Additionally, in portal frame buildings 32m or longer, this vertical cross bracing shall be installed in internal bays. With 6.4m bays, bracing shall be installed in every second bay; with 4.8m bays, bracing shall be installed in every third bay. For bay widths of 6.0m and above the vertical-cross bracing shall consist of 70 x 70 x 6mm angle secured to the rafters by 16mm bolts, and similarly fastened to each other at the cross-over point.

## **A.6 TIMBER STRUCTURED DESIGN – GENERAL**

**A.6.1** All structural timber to be strength class C16 minimum Irish Sitka spruce or equivalent and to comply with the latest edition of IS 444. The moisture content, at time of erection, shall not exceed 20%.

**A.6.2** All timber is to be vacuum/pressure treated with an approved preservative. Such treatment shall ensure a preservative loading and concentration to provide a minimum service life of twenty years to satisfy hazard class 4 requirements, as defined in IS EN 335-1:1992. Following treatment, any areas of timber revealed by cross cut, holes, notches etc. shall be brushed with an approved end grain preservative. (Timber which is rip sawn, equalised, planed or heavily sanded shall be returned to the treatment plant for re-treatment before use).

Advice on the use and handling of preservative treated timbers shall be sought from preservative manufacturers/suppliers, and followed.

It may be necessary to prevent housed animals from licking/chewing chemically treated timber. In such circumstances, the treated timber structural members within reach of the animals shall be shielded. Where it occurs, steel/plastic/ aluminium angles shall be fixed to the corners of the timber members accessible to the animals, for a height of 1.8m minimum, or an alternative shielding system shall be provided, subject to acceptance.

**A.6.3 All plywood shall be Canadian Douglas Fir or spruce plywood select sheathing grade.** Plywood shall comply with BS 6566: Part 8, as modified by BS 5502: Part 22. All plywood shall have weather and boil proof (WBP) bond, suitable for exterior use.

**A.6.4** All bolts, nails, timber connectors or other fasteners shall be galvanised or sheradised in accordance with BS 5493.

**A.6.5** A numbered Certificate, dated, signed and stamped by the Timber Treatment Plant, shall be presented for all grant-aided structures, certifying that the timber supplied has been fully treated with the type and level of preservative treatment specified in A6.2 above. This Certificate shall list all structural timber supplied for the building and the date delivered on site.

Where a contractor/fabricator supplies timber direct, then this contractor/fabricator shall certify under his/her company letterhead signed and stamped, the name and address of the Timber Treatment Plant, the date and number of the invoice/advice note which refers to the timber treatment provided, as specified in clause A6.2 for the particular timber superstructure.

**A.6.6 Simple Timber Frame.** Simple Timber Framed Structures may be used for single and double-sided houses with a maximum bay width of 4.8m and a maximum span of 4.5m. Rafter spacings are a maximum of 1.6m.

**Table 12 Timber member sizes**

Span	Bay Width	Structural Elements	Sizes in mm
up to 4.5m	4.8m	Column1	225 x 150
		Rafters2	175 x 75
		Eaves & Internal Bearers	225 x 75
		Knee Braces	100 x 75 & 175 x 75
		Gusset Plate3	18mm plywood
		Purlins	75 x 44
		Cladding Rails	150 x 75
		Stock Walling	100 x 22

**Note:**

1. Timber column may be constructed from two No. 225x75 (Figure 16).
2. Rafter spacing @ 1.6m centres (three No. per 4.8m bay width)
3. Knee brace gusset plates to be fixed at column bearer junctions (Figure 20)

**A.6.7 Assembly Of Timber Columns.** Timber sections shall be bolted together with 12mm galvanised/sheradised bolts. Bolts to be 200 mm long, fitted with galvanised washers at both ends. Bolts to be at a maximum spacing of 600 mm.

Top of column to be tapered to suit rafter slope and to be rebated to carry 225mm x 75 mm eaves/internal timber bearers (Figure 16).

**A.6.8 Timber Column Fixing To Foundations Column** shall be finished 75mm above finished floor level. A 254mm x 102mm x 22Kg. UB steel section (galvanised), at least 1600mm long shall be used to connect timber columns to concrete foundation block. The UB section shall be set at least 625mm in the concrete and the timber column to be bolted to the web of UB section with 4 No. galvanised bolts (Figure 16).

**A.6.9 Timber Column/Bearer Connections.** Eaves bearer 225mm x 75mm shall be fixed to downslope side of external columns. The column head shall be recessed 75mm from outside face and 175mm deep to carry eaves bearer. The bearer shall be secured to column with a galvanised angle plate each side of the column (Figure 18).

A 19mm triangular plywood gusset plate shall be fitted to the column / bearer joint (Figure 20). Gusset plates shall be nailed at joint with 35mm flat headed galvanised nails to the pattern detailed.

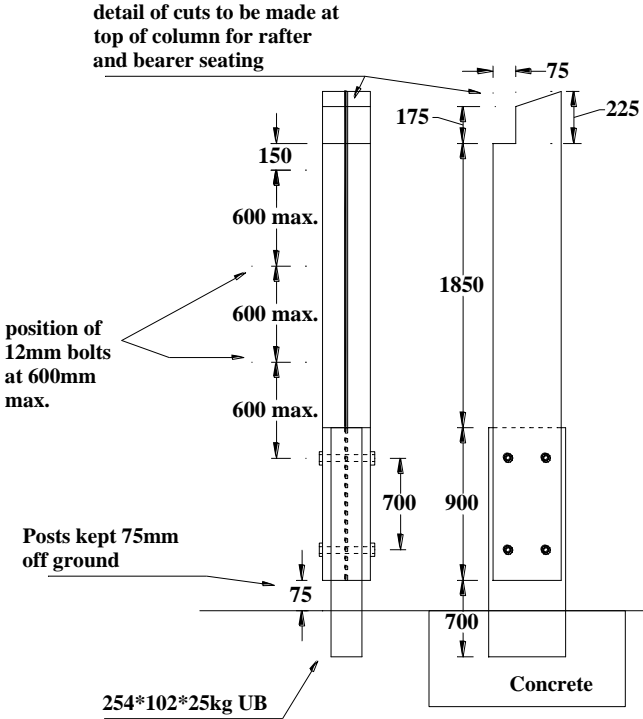
The internal bearer shall be fixed to the upslope side of the internal columns as per above specification.

Rafters shall be fixed to column head and to bearers with galvanised rafter straps fixed to each side of rafter and anchored to gusset plates. Straps to be fixed to gusset plates with 35mm long flat-headed galvanised nails (Figure 20).

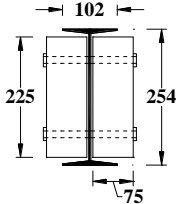
**A.6.10 Apex Gusset Plates.** On all doubled sided houses, rafters at the apex shall be secured to each other with 18mm plywood gusset plates. A gusset plate shall be fixed to each side of rafter with 35mm flat-headed galvanised nails (Figure 21).

**A.6.11 Timber Purlins.** Timber purlins 50mm x 75mm at 1.64m centres maximum shall be fixed to rafters with galvanised straps nailed to purlin and rafter with 25mm galvanised nails. Where purlins are lapped, they shall be lapped over a rafter. The lap length shall be a minimum of 300mm secured with 25mm long galvanised nails. The lapped joint shall be fixed to the rafter with a galvanised angle plate, one on each side of the lapped joint (Figure 18).

**A.6.12 Space Boarding Ventilation / Timber Stock Boarding.** Where inlet ventilation is provided by Yorkshire style boarding then Clause B2.4 of this specification shall be followed. Back wall and gable walls of 100mm x 22mm stock boarding prefabricated panels may be used. Stub timber columns, 75mm x 150mm, shall be erected at a maximum spacing of 2.4m to support the prefabricated panels. Stub columns shall be fixed to concrete foundations as per Clause A6.4 above.

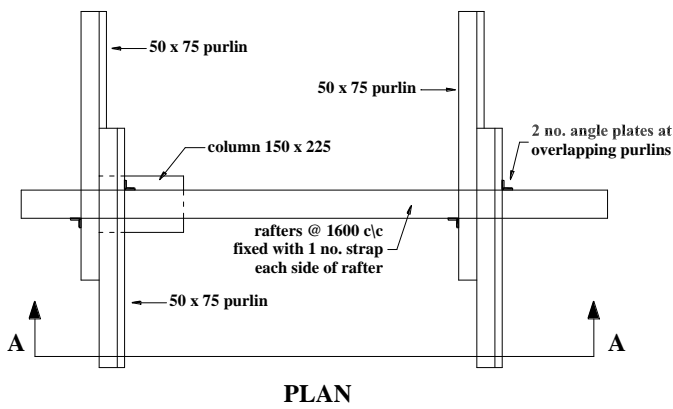
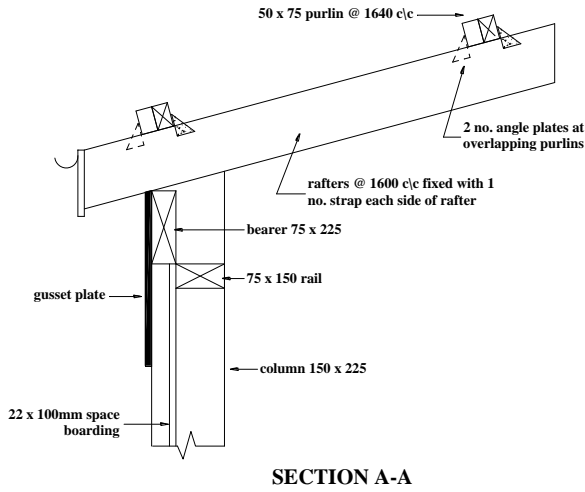


**Figure 16 External column**

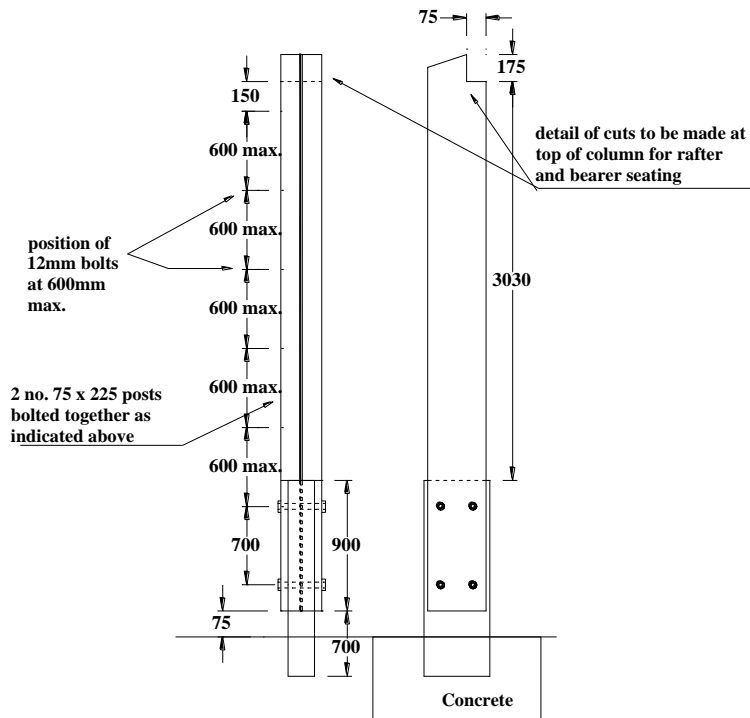


**Figure 17 Column: Section**

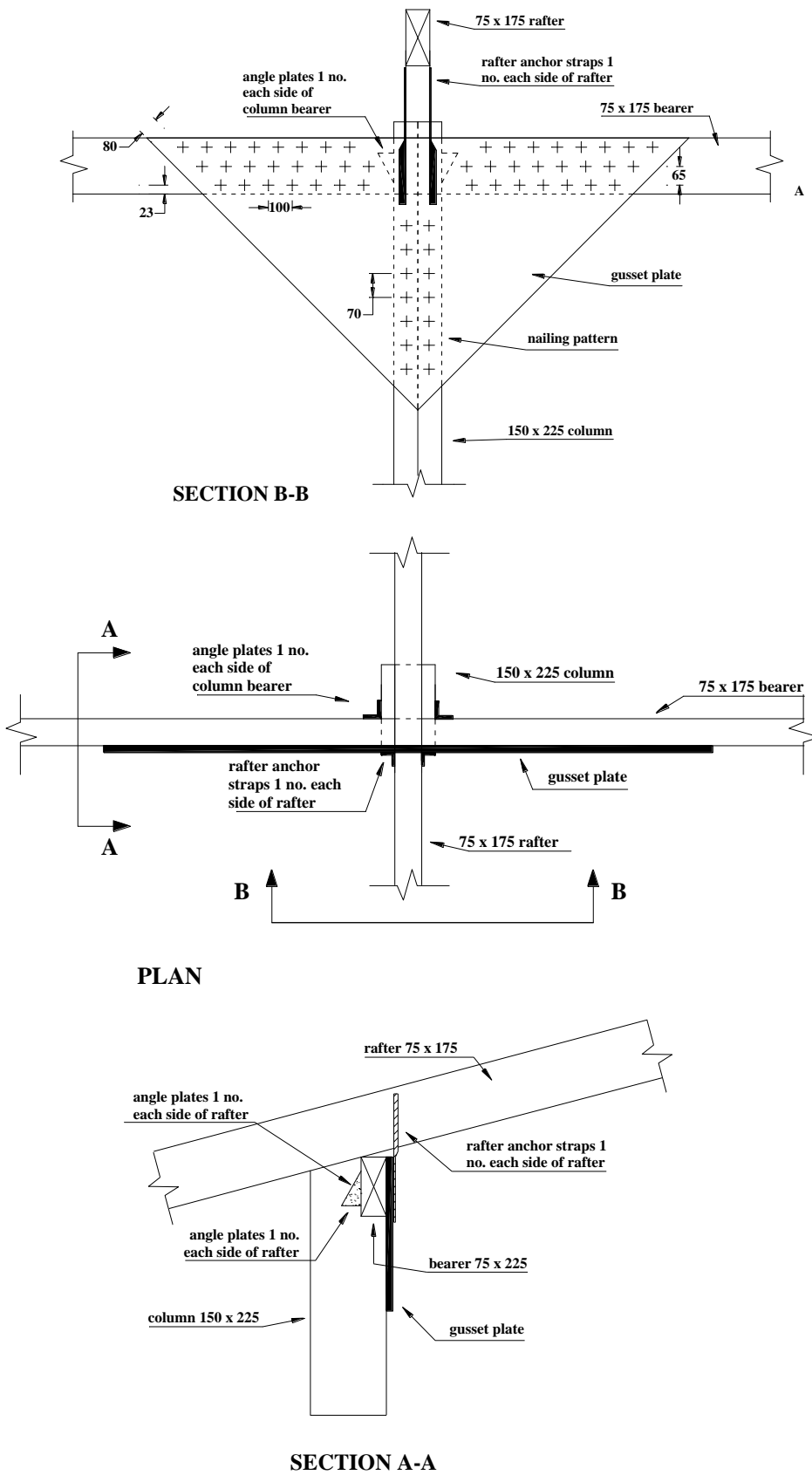




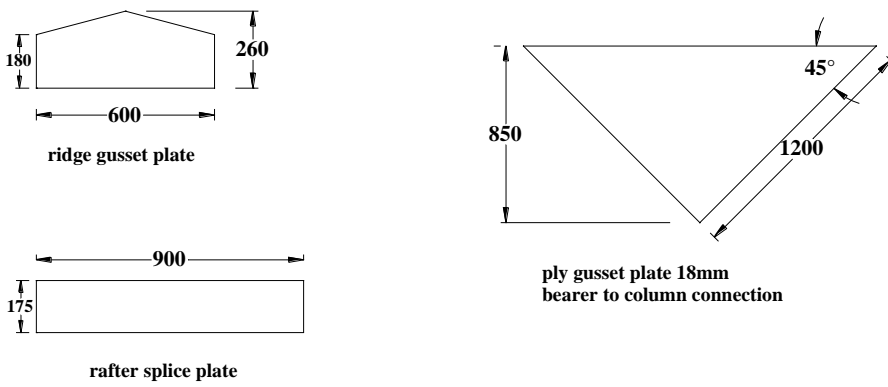
**Figure 18** Top of external column / fixing of purlins



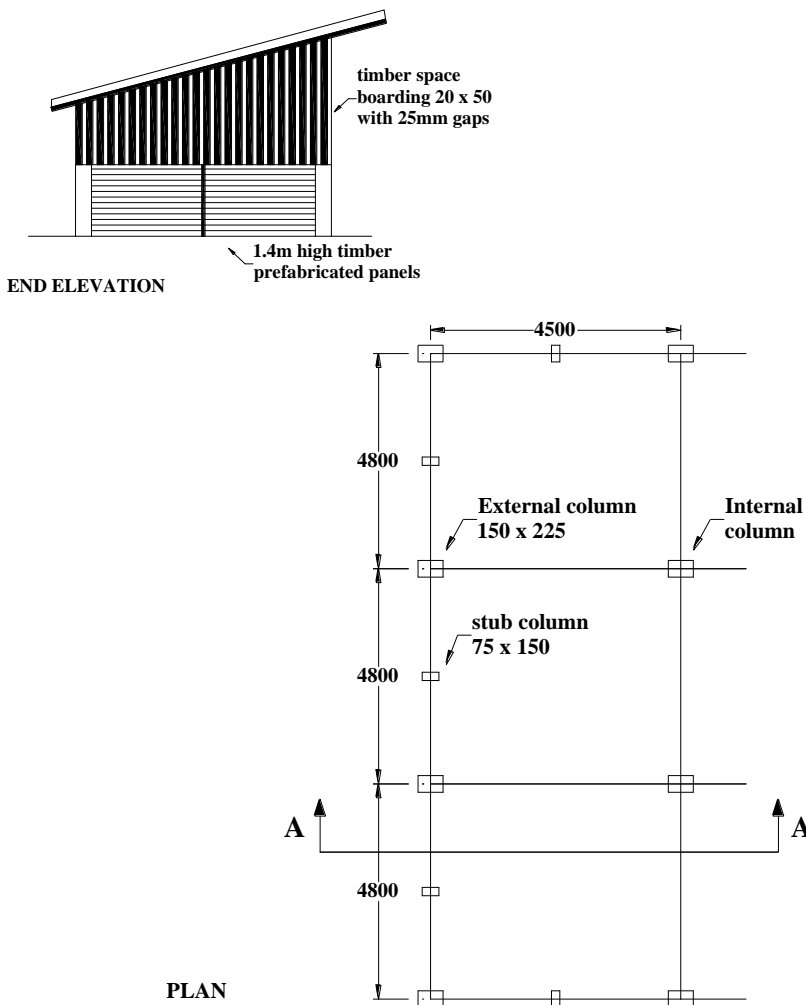
**Figure 19** Internal column



**Figure 20 Top of internal column: connections**



**Figure 21 Gusset details**



**Figure 22 Plan and end elevation of timber building**

### **A.7 TIMBER PORTAL FRAME**

Note: Where timber portal frames or a combination steel/timber portal frames are proposed for grant aided structures then the detail design, drawings, calculations and specification must be submitted by the Applicant/Planner to the Department for prior acceptance before any work on site is commenced. The same procedure shall be followed if it is proposed to construct a wide span timber truss roof.

### **A.8 TRADITIONAL SOLID WALL AND TIMBER ROOF**

**A.8.1** A building with load-bearing walls may be constructed with spans up to 6.75m. Walls shall be a minimum 200mm, solid concrete block with solid blockwork piers where necessary, or of mass concrete. DPC shall be provided at floor level in all blockwork walls. Internal partition walls shall be a minimum 150mm solid concrete block. For concrete block walls in houses with spans of 5m or greater, reinforced concrete ring beams 200mm x 200mm shall be placed horizontally along the top of the wall and tied back 450mm into the gable. All blocks shall be certified to a minimum strength of 7.5N/mm<sup>2</sup>, Category 1 blocks and shall be produced in a plant certified to EN 771-3:2011 and shall be CE marked. The use of hollowcore blocks is not permitted.

**A.8.2** Roof carassing to load-bearing walls. Monopitch timber roofs shall have a minimum pitch angle of 15°. Rafters shall be at 1.8m centres and sized as follows:

**Table 13:**

Span (m)	Under 5.0	>5.0 - 5.5	>5.5 - 6.4	>6.4 - 6.75
Rafter Size (mm)	150 x 75	175 x 75	200 x 75	225 x 75

Purlins shall be 75mm x 50mm at 1.2m centres.

**A.8.3** Pitched roofs of traditional timber framing may be used for spans up to 6.75m. The pitch angle shall be between 20° and 25°. Rafters shall be at 1.3m centres and shall be sized as follows:

**Table 14:**

Span (m)	Under 5.0	>5.0 - 5.5	>5.5 - 6.75
Rafter Size (mm)	100 x 50	125 x 75	150 x 50

Collar ties shall be 100mm x 50mm and secured rigidly to the rafters at mid point. Purlins shall be 75mm x 50mm, spaced at 1.2m centres. Wall plates shall be 100mm x 75mm secured to the wall at 2m intervals. Slates and roof tiles, where used, shall be fixed in accordance with manufacturer's/supplier's instructions, and purlins installed and spaced to manufacturer's instructions.

Where it is desired to construct a Traditional Solid Wall and Timber Roof structure that is large than specified above, full structural calculation shall be submitted in accordance with Clause A1.2.

### **A.9 CONCRETE FRAMED STRUCTURE**

Where concrete frames are proposed for grant aided structures then the detail design, drawings, calculations and specification must be submitted to the Department by the specialist company who manufacture and erect the structure for prior approval before any work on site is commenced.

Note: Concrete framed structures shall be designed to the relevant European Standard for such structures. In particular to I.S. EN 13225:2013 and shall be CE marked and have an accompanying

Declaration of Performance and produced in a plant certified by a Notified body (e.g. NSAI or equivalent) to produced precast concrete framed elements.

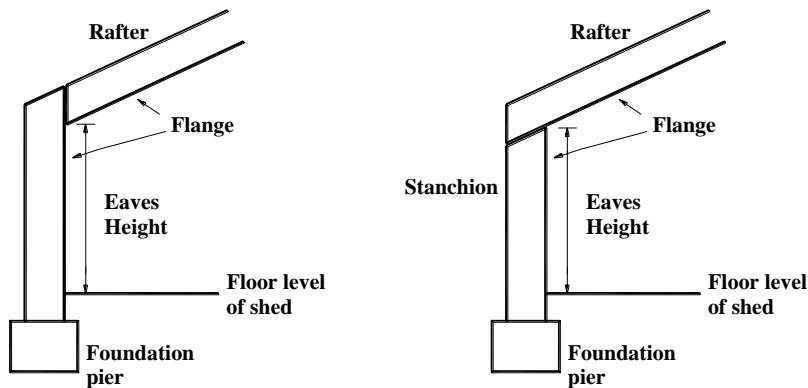
#### ***A.10 STEEL HOOPED STRUCTURE (polytunnel)***

Where it is desired to construct a steel hooped structure (polytunnel), a full set of design drawings (including details of steel sizes and joint details) and full structural calculations for the entire building shall be prepared by a Chartered Engineer, and given to this Department for prior approval before the start of construction. The design of the building shall be in accordance with IS EN 1993: Eurocode 3: Design of steel structures and loadings shall be to IS EN 1991 and BS 5502 Part 60.

## B. GENERAL CLAUSES FOR ALL BUILDING TYPES

### B.1 EAVES HEIGHT & ROOF SLOPE

Eaves height is defined as the distance between the underside of the rafter where it meets the outer stanchion and the internal floor of the building. All houses for animals shall have a minimum eaves height of 3m, except milking premises and dairies where 2.75m is permitted, or where it is permitted within the individual specification for the house type. In loose and creep houses an eaves height of 4m is recommended to facilitate machinery usage.



**Figure 23** Interpretation of eaves height

#### B.1.1 Roof Slope

The roof slope for all livestock buildings, or for any buildings in which livestock may eventually be housed, shall be a minimum  $15^\circ$  (equivalent to a 270mm rise per 1m span). However, for monopitch livestock units, non-livestock buildings and also for any livestock unit with spaced roof sheeting, the slope may be reduced to a minimum  $12^\circ$  (equivalent to a 215mm rise per 1m span).

## B.2 VENTILATION

**B.2.1 Proper Ventilation** shall be provided to all livestock buildings as a strict condition of grant-aid, in order to protect animal health and the working life of the structure. The minimum requirements outlined below shall be followed for housing for dairy cows, suckler cows, beef cattle, calves, sheep, and deer. Full ventilation shall also be provided in any conversion or extension of existing buildings. Department specifications for the housing of horses, goats, pigs and poultry shall be followed separately.

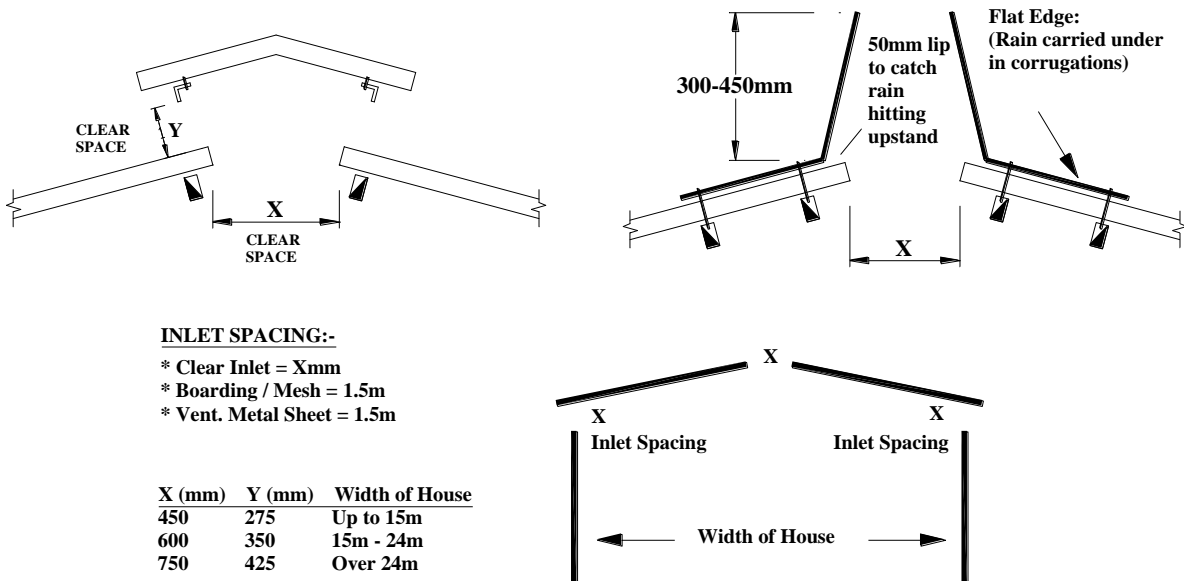
**B.2.2 Outlet Ventilation** shall be provided along the full length of the roof apex; 450mm wide for a house up to 15m wide; 600mm wide for a house up to 24m wide; and 750mm wide for larger houses. A ridge cap over the outlet is not recommended, but when provided it must stand unobstructed and fully clear of the roof by 275mm, 350mm, or 425mm respectively, for the three widths of houses noted above (denoted by “Y”, Figure 24).

Curved or angled upstands placed on the roof on both sides of the ridge outlet improve the ventilation and prevent most rain access. This is a strongly recommended alternative to ridge

capping. Under such upstands, the roof-sheet shall extend 50mm on each side to prevent rainwater dripping from the upstand (Figure 24).

Where spaced sheeting with a gap of at least 20mm is installed over the entire roof, then a central ridge outlet, though recommended, is not mandatory. Monopitch buildings, if fitted with a front canopy, shall have a min. 275mm wide outlet along the length of the roof, positioned near the highest point.

**Note:** Spaced sheeting is mandatory for any new roof in extension or conversion work where a full ventilation outlet is not available.



**Figure 24 Ventilation details**

**B.2.3 Outlet Ventilation in Curved Roofs.** Outlet ventilation in all new roofs shall be achieved by spaced sheeting over the entire roof with a minimum gap of 20mm. When conversion work is being done to bring an existing curved-roof building into animal production, in each bay two non-adjacent sheets at the apex of the roof are to be raised for at least one-third of their length. Using timber or (preferably) angle iron spacers, each sheet shall be lifted to provide a clear space on all sides of at least 275mm.

**B.2.4 Inlet Ventilation** shall be provided directly under the eaves for the full length of each side of the house, or the lower side of a mono-pitched house. An unobstructed depth of 450mm shall be provided in houses up to 15m wide; 600mm deep in houses up to 24m wide; and 750mm deep for larger houses. A roof overhang of 400mm is recommended when unobstructed inlet ventilation is used.

To reduce wind-speed and rain, pre-painted steel sheets with ventilation slots (vented sheeting) over their surface are recommended for inlet ventilation, provided they are listed in Specification S102. They shall be positioned immediately below eaves for the full length of the house and have a minimum depth of 1.5m. For buildings over 15m wide and less than 24 m wide, there shall be an unobstructed opening of at least 300mm above the 1.5m vented sheeting and this opening shall be increased to not less than 450mm for buildings over 24m wide.

In bovine and sheep houses, particularly in wide span houses, it is very strongly recommended that ventilated sheets should be used for gable cladding. [There is a standard grant-aid allowance to cover the extra cost of the sheets.]

Spaced (Yorkshire) boarding or fabric/plastic mesh may also be used in the side inlet gap. These shall also be installed with a minimum depth of 1.5m along the full length of the house. Boarding shall consist of treated timber laths secured at the top to roof timber and at the bottom to a 150 x 75mm cladding rail. Laths shall be 25mm thick and a maximum width of 75mm: Gaps between laths shall be at least 25mm. Spaced boarding may also be installed in place of gable cladding.

Approved fabric or plastic mesh shall be secured in accordance with manufacturers' instructions. Such materials shall be guaranteed for 10 years in normal working conditions. These materials shall not be used above eaves level on gable ends.

Where the inlet ventilation of an existing building is impaired as a result of the presence of an adjoining new building, then the inlet ventilation provided in the new structure shall be sufficient to ventilate both buildings simultaneously. The ventilation spacings shall be sized for the combined structure and not just the new part. This may involve removing the cladding on that part of the original structure that is common with the new building, and increasing the inlet ventilation of the existing building.

Where sliding doors are present on sidewalls, the inlet ventilation requirements for that sidewall shall also apply to the sliding doors. Therefore, if for example ventilated side cladding is present, then the doors shall also incorporate this form of cladding. This also applies to unobstructed ventilation: the top part of the door shall be left open.

**Note:**

For side inlet ventilation spaced sheeting is inadequate, and is not permitted for such use

There is a type of inlet ventilation whereby the side cladding sheet is canted outwards to form a gap between the bottom of the sheet and the wall. This type of inlet ventilation is not permitted on its own.

## **B.3 PROTECTION OF STEEL**

### **B.3.1 Structural Steel shall be protected as follows:-**

#### **SYSTEM I: Hot Dipped Galvanising:**

Hop dip galvanised coating shall be applied **after fabrication** in accordance with I.S. EN ISO 1461:2009 to a minimum average coating weight of 610gr/m<sup>2</sup>.

Small areas of galvanised coating damaged by any subsequent welding, cutting, or by excessively rough treatment during transit and erection may be renovated by the use of at least 2 coats of "spray-on cold galvanising" supplied by the galvanising company; or at least 2 coats of zinc-rich paint/primer complying with BS 4652: 1995, or 2 coats of 'ZINGA', [Agreement Certificate No. 94/3042].

Where a building is located less than one kilometre from the coast, it is recommended that all steel work is shot-blasted prior to hot-dipping so as to enable the steel to have a higher costing of zinc applied.

**Note:** Hot Dipped Galvanising is strongly recommended and shall be undertaken in cases where the applicant manufactures the steel frame themselves.



**SYSTEM II: Shot-blasting, Priming, and Painting:**

All scale and rust shall be removed by shot-blasting to Sa 2.5 or ISO 8501-1:2007. A holding zinc-rich primer of 25 microns shall be applied within 12 hours of shot-blasting. A further 50 microns of primer, and 50 microns of micaceous iron oxide finishing coat, shall provide a total dried coat of minimum 125 microns. (80 microns in two coats of the proprietary paint “ZINGA” can be used as an alternative on shot-blasted steel to the above standard).

**B.3.2 Damage to Paint Surfaces:**

Any damage to paint surfaces during transport or site erection shall be made good by brush treatment on site using specified primer and furnishing coats.

**B.3.3 Certificates:**

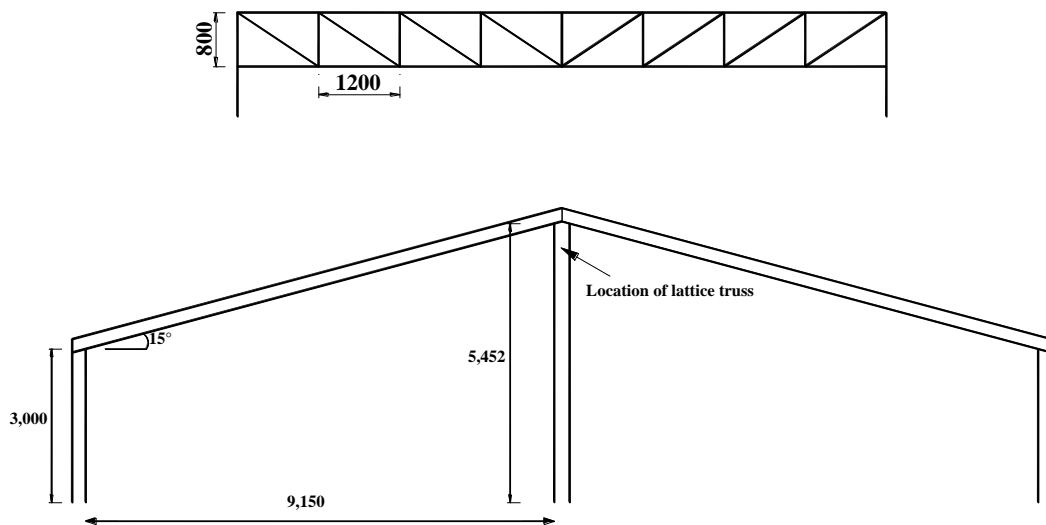
Certification shall be supplied from steel fabricators or contractors that painting or galvanising has been carried out to the specified standards on the whole superstructure in question. Where galvanising has been used, the certificate supplied by the fabricator/contractor shall state the name and address of the Galvaniser, and date and number of invoice/advice note which refers to the particular superstructure. The wording of the certificate shall be as given in the sample certificate on the website, and the certificate shall be on the manufacturer’s headed paper (clause B16).

**B.3.4 Treatment of non-structural steelwork**

It is strongly recommended that all non-structural steel work is hot-dip galvanised to I.S. EN ISO 1461:2009. All non-galvanised non-structural steelwork shall be prepared and given a primer coat and 2 coats of long life lead-free paint.

**B.4 STANCHION ELIMINATION**

Where it is essential to eliminate a stanchion in order to yield more unhindered floor space, a lattice truss or steel beam shall be provided to span not more than two standard bays. Such lattice trusses shall be a minimum of 800mm deep. The detail design, drawings, calculations and specification of such a lattice truss shall be submitted by the Applicant/Planner to the Department for prior acceptance before any work on site is commenced.



**Figure 25 Lattice truss detail for back-to-back lean-to**

However, in a simple steel frame structure or a back-to-back lean-to, where spans are not greater than 9.15m, and the bay width not more than 4.8m (eaves height 3m), an IPE 270 beam shall be used. The two stanchions supporting this beam 9.6m apart shall be sized as IPE 270 also. The joint connecting the beam to the stanchions shall be braced as per section A5.3.

Alternatively where a truss is used, the top member size shall be 80 x 80 x 8mm; bottom member 50 x 50 x 6mm; and internal members 50 x 50 x 6mm. Stanchion size shall be IPE 220 as per Table 4.

**B.5 GRAFTING ONTO STANCHIONS**

Grafting should be avoided but in circumstances where it is used then the following conditions shall be strictly observed:

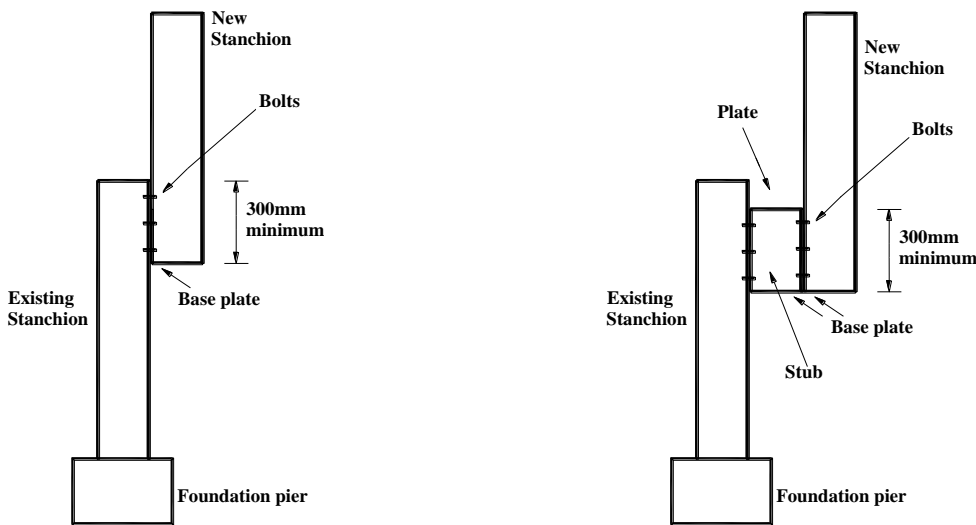
The stanchion of the existing building, to which the stub stanchion of the new building is being grafted, shall be of sufficient size for both the existing building and the new one. The stanchion and the base connection at ground level shall show signs of only minimal corrosion

The overlap of both stanchions shall be a minimum 300mm deep

The connection shall be secured by 6 No. 16mm bolts

A maximum of one stub (same size as new stanchion) between the old and new stanchions is permitted. A base plate (min. 12mm) shall be welded to both the bottom of the stub and new stanchion (see Figure 26). A plate shall also be welded to the top of the stub

Note: Grafting to a stanchion formed from a railway track is not permitted.



**Figure 26 Grafting Detail**

**B.6 CONCRETE SPECIFICATION**

**B.6.1 Certificates**

Concrete shall be produced in an audited plant only: it shall not be produced on site.

A numbered certificate, signed and stamped, shall be required for all concrete delivered to site. The certificate, the "Concrete Manufacturers' Specification Certificate", is produced in triplicate. The top certificate, printed on light blue paper, shall be retained by the applicant and given to the

Agriculture, Environment and Structures (AES) Division of the Department of Agriculture for inspection upon completion of the works.

### **B.6.2 Curing of Concrete**

**Concrete produced and supplied is fit for purpose ONLY IF proper curing procedures are adhered to and the structure is not put into service until an adequate curing time (usually a minimum of 28 days) has elapsed.** The curing regime shall take account of best practice appropriate to the concrete binder composition and prevailing climatic conditions at time of placing.

All concrete shall be cured by keeping it thoroughly moist for at least seven days. Wetted floor slabs and tank walls shall be protected by polythene sheeting, kept securely in place. Alternatively proprietary curing agents may be used in accordance with manufacturer's instructions. When frost is a danger, straw bales shall be placed over the polythene on slabs. Concrete shall be at least 28 days old before being subjected to full load, or to silage or silage effluent.

For further information on curing, see the website of the Irish Concrete Society.

**B.6.3 Concrete for Silage Effluent.** For **purpose-built** silage effluent tanks and channels, concrete shall be purchased on the basis of a characteristic 28 day cube crushing strength of  $45\text{N/mm}^2$  (strength class C35/45). Minimum cement content shall be  $360\text{ kg/m}^3$ . The maximum water to cement ratio will be 0.5. The specified slump class shall be S2 or S3. Maximum aggregate size shall be 20mm.

**The concrete shall be ordered using the appended form for 'S.100 Mix A' or by requesting '45N concrete with 360kg cement minimum, 0.50 water cement ratio maximum, and slump class S2 or S3, certified to IS EN 206, for use to Specification S.100'.**

If the Concrete Supplier requires further information the following shall be quoted to them:

- The concrete is to be to I.S. EN 206-1:2002: Strength Class: C33/45, 360 kg cement, maximum water cement ratio of 0.50, Exposure classes: XA3, XC4 (25 year life), Slump class: S2 or S3, maximum aggregate size 20mm.

If plasticised concrete is desired, the slump class shall not exceed S3.

**B.6.4 Concrete.** For all other purposes including slurry tanks to which silage effluent may be directed, concrete shall be purchased on the basis of a characteristic 28 day cube crushing strength of  $37\text{N/mm}^2$  (strength class C30/37). Minimum cement content shall be  $310\text{ kg/m}^3$ . The maximum water to cement ratio will be 0.55. The specified slump class shall be S2 or S3. The maximum aggregate size shall be 20mm.

**The concrete shall be ordered using the appended form for 'S.100 Mix B' or by requesting '37N concrete with 310kg cement minimum, 0.55 water cement ratio maximum, and slump class S2 or S3, certified to IS EN 206, for use to Specification S.100'.**

In the case of exposed yard slabs where freeze/thaw action is a concern, 'S.100 Mix B' shall be used with 3.5% minimum air entrainment. Alternatively 'S.100 Mix A' may be used.

If plasticised concrete is desired, the slump class shall not exceed S3.

**B.6.5 Fibres.** Polypropylene fibres may be incorporated into the concrete mix to improve the properties of concrete. Only fibres which have been tested and approved by National or European approval authorities may be used. The use of fibres helps to reduce plastic cracking and improve

surface durability but they are not a substitute for structural reinforcement. Fibres shall be used in strict compliance with manufacturer's instructions, and shall only be added at the concrete manufacturing plant. The concrete certificate shall clearly show the amount and type of fibre added. The mix design, compacting, and curing of fibre concrete is the same as concrete without fibre.

**B.6.6 Self-Compacting Concrete.** Self-compacting concrete (SCC) may be used in vertical elements only. SCC must comply with all requirements of this specification, except for the slump class which must meet slump flow class SF2. SCC shall be produced by a manufacturer with experience in producing SCC and should be placed by a contractor with experience using SCC.

If it is proposed to use SCC, additional guidance shall be sought by the contractor undertaking the works. Particular care must be taken in the use of fully sealed formwork, designed to withstand the higher hydrostatic pressure exerted by SCC. Guidance can be obtained from the Irish Concrete Society website ([www.concrete.ie](http://www.concrete.ie)).

**B.6.7 Materials.** Cement and other materials used in the production of concrete shall be in accordance with Department of Agriculture, Food and the Marine specification S.100.

Plasticisers and other admixtures shall be to EN 934. All admixtures shall be used in strict accordance with manufacturer's instructions, and shall be added only by the concrete-mix manufacturer.

**B.6.8 Tests.** The Department reserves the right to require that concrete should be tested in accordance with EN 12390 and EN 12504.

## **B.7 CONCRETE FOUNDATIONS**

**B.7.1 Foundation Piers for Stanchions:** Stanchions shall be carried on, or built into a concrete pier minimum 600 x 600mm that is carried up from solid strata, and is at least 600mm deep. For structures with spans greater than 12m and in all portal frames, the concrete foundation pier shall be 900 x 900mm that is carried up from solid strata, and be at least 900mm deep. Where there is no mass concrete floor in the building, the foundation piers shall be increased to 900mm x 900mm x 900mm deep for spans up to 7.6m, and to not less than 1200mm x 1200mm x 1200mm deep for spans greater than 7.6m.

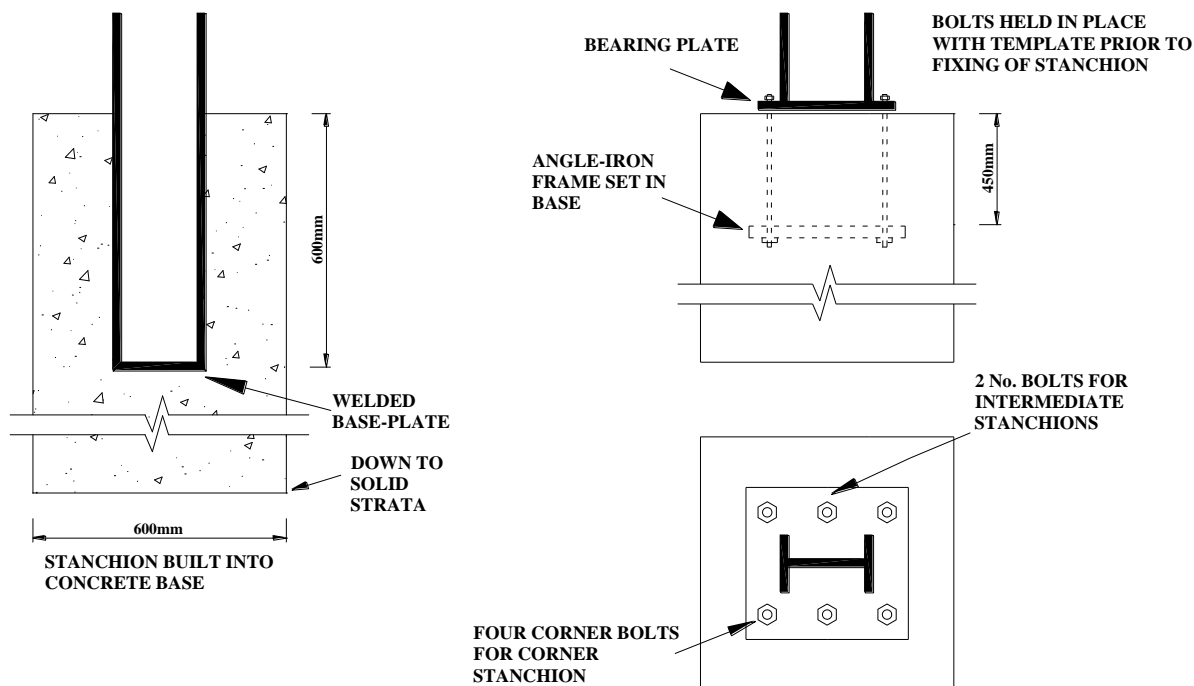
**Note:** For stanchions erected, or portal frames carried, on tank walls, see Clauses 8.3, 8.4 and 8.5 of S.123.

The stanchions shall be inserted into the piers a minimum depth of 600mm or alternatively, shall be secured to the piers in an approved manner using steel base plates (min. thickness 12mm) welded to the base of the stanchion, and holding down bolts. Corner stanchions shall be bolted down with 4 No. 20mm holding down bolts, 450mm long. Bolts holes in base plate to be a minimum of 40mm in from either edge of plate. Base plates for intermediate stanchions shall be bolted down with 2 No. 20mm holding down bolts, 450mm long. Bolt holes in plate to be a minimum of 40mm from edge of plate and set at centre of stanchion web (Figure 27).

Holding down bolts shall be secured into foundation pier by using 75mm x 75mm steel angle which is drilled to accommodate the bolts. The bolts are then threaded through and fixed securely in foundation pad before pouring concrete. A suitable template shall be used, to keep bolts in correct position for base plates during pouring concrete (Figure 27).

Where stanchions are offset in foundation blocks, reinforcement shall be used in the foundation.

**Note:** Patent anchor bolts may be allowed in place of cast-in bolts, provided they are sized, and installed, in strict accordance with the manufacturer's specifications and instructions.



**Figure 27 Stanchion base and pier details**

**B.7.2 Concrete Foundations for Mass Concrete and Block Walls.** In undisturbed ground, foundations shall be excavated down to solid strata for a minimum width of 600mm and a depth of 300mm.

Where backfill material is used under infill walls, the backfill material shall be thoroughly compacted in layers not exceeding 150mm before foundations are laid. Foundations shall be formed in concrete at least 300mm deep and 600mm wide. It is recommended that steel reinforcement bars (a minimum of 4 No. 12mm bars, fixed 50mm from bottom of concrete) should be incorporated into concrete foundations on compacted backfill.

In cases where fill is purchased for use under concrete, it shall be certified to EN 13242:2013 and meet the requirements of Annex E of S.R. 21: 2015. This material shall also be used as the top 300mm of any backfill around stanchion foundations.

**B.8 CONCRETE FLOORS**

Solid Floors shall be a minimum 125mm concrete laid smooth with a non-slip finish. Concrete shall comply with Clause B6 above. A minimum 150mm hard-core base shall be laid, compacted with vibrating or heavy roller, and topped with fine sand. All floors shall incorporate 1000 gauge polythene DPC membrane with 600mm overlaps laid on the sand under concrete. The polythene membrane shall be taken up along walls to meet DPC where this has been installed.

**B.9 MASS CONCRETE / BLOCKWORK WALLS**

Note:

- Walls are not mandatory for bovine houses other than calf/suckler houses (see Specification S.123), or for sheep houses. Barriers may be used instead. (Evidence suggests that animals

may be healthier in such houses.) When installed, wall heights for animal houses are to be chosen to allow the appropriate ventilation above them (clause B2). Such walls will normally not exceed 1.5m in height.

- For walls erected on tank walls, refer to Specification S123.
- It is strongly recommended that all walls are of mass concrete or precast concrete.

**B.9.1 Non Load-bearing superstructure walls.** Where stanchions are at 4.8m spacing or less, the infill wall shall be a minimum of 150mm thick. Where stanchions are spaced between 4.8m and 6.4m, then the wall thickness shall be at least 200mm.

**B.9.2 Proprietary precast concrete wall panels** shall require prior Departmental acceptance and be listed on specification S101A of the Department of Agriculture, Food and the Marine. All Proprietary precast concrete wall panels shall be CE marked and produced in a plant certified by a Notified body (e.g. NSAI or equivalent), to produce precast concrete wall panels to EN 14992:2007 +A1:2012.

**B.9.3 Mass concrete walls.** Mass concrete in-fill walls shall be constructed with nominal mesh reinforcement. (Minimum mesh A98: 5mm at 200mm x 200mm; 1.54kg/m<sup>2</sup>). Mesh shall be placed on outside face of wall with 40mm concrete cover. It is strongly recommended that gable walls should be in mass concrete. Any blemishes, tie-bar holes, or honeycombing in mass concrete walls shall be filled/repared with an accepted, non-shrink proprietary cement mortar.

**B.9.4 Block walls.** All block walls shall be of solid blocks that are certified to a minimum strength of 7.5N/mm<sup>2</sup>, though it is strongly recommend that they be constructed of mass concrete. All blocks used shall be Category 1 and produced in a plant certified to EN 771-3:2011 and shall be CE marked. The use of hollowcore blocks is not permitted.

**B.9.5 Tying-in walls to stanchions.** In-fill walls shall be built into and secured to the web of the stanchion. Where walls abut the flange of the stanchion an angle section shall be welded to both edges of the flange to form a recess for the wall. These angle sections shall extend from 450mm above wall foundation to the top of wall. To minimise corrosion a continuous weld shall be used. The weld shall be protected with a coating to clause B3. Alternatively, they shall be secured to the flange with 10mm steel dowels, 225mm long at a maximum vertical spacing of 450mm.

**B.9.6 In gables,** stanchions to support the gable walls shall be erected from the foundation and be secured to the steel rafter or to a steel cross beam at approximately wall height. For 150mm walls, spacing of these stanchions shall be 5m maximum, and for 200mm walls the maximum spacing shall be 7m. Stanchions shall also be positioned at openings for central passage doors.

**B.9.7 All block walls in animal houses, dairies and milking premises** shall be rendered internally with two coats, 12mm and 6mm respectively, with 3:1 sand cement rendering with plasticiser or ¼ part lime, to a smooth steel trowel finish. Block walls shall be rendered externally with one coat 12mm thick to a nap or smooth finish.

## **B.10 ROOF CLADDING & SIDE CLADDING**

**B.10.1 Non-fragile roofs** shall be installed over all agricultural buildings except for polythene-covered hooped structures. The entire assembled roof shall have a non-fragility rating of at least

CLASS C as defined in “ACR[M]001:2014: Test for fragility of Roofing Assemblies.” All metal cladding and reinforced fibre-cement cladding listed in S102 will achieve CLASS C provided they are assembled in accordance with the manufacturer’s instructions. Rooflights listed in S102 shall be installed to manufacturer’s instructions to achieve CLASS B non-fragility. All cladding listed in S.102 may be used for spaced-sheeting of roofs, although full CLASS C non-fragility cannot be guaranteed in all cases, for spaced sheeted roofs.

**B.10.2 Single Sheet Cladding Materials and Rooflights** shall comply with the current edition of Specification S.102, and shall be fixed in accordance with manufacturer’s instructions. All flashings used shall be to the same standard at the main cladding sheets.

**B.10.3 Double-skin insulated Metal Roof Sheets** of proprietary manufacture may be used in dairies, milking premises, produce stores and pig and poultry buildings once they are listed on S.102. Sprayed polyurethane foam may also be applied to single sheet cladding in such stores, provided there is no risk of mechanical damage to the foam.

**B.10.4 Spaced Roof Sheeting** shall normally require that cladding materials be specially ordered. The cladding material must have an equal upstand on each side of the sheet.

**B.10.5 Side cladding.** To prevent personal injury, side cladding shall not be finished within the range 0.9m to 2.1m from ground level in any building unless a wall or fixed barrier is located below the cladding.

## **B.11 PURLINS, SIDE RAILS & FIXING OF CLADDING**

**B.11.1 Timber Purlins** may be used in all framed structures with bay widths up to 4.8m. They shall be 175mm x 75mm at a maximum spacing of 1.4m centres for fibre-cement cladding and double skin insulated cladding; and 150mm x 75mm at a maximum spacing of 1.8m centres for all single-sheet steel cladding. Additionally, the purlin spacing shall not exceed that specified for the particular cladding as listed on S.102 (this is 1.5m in many cases). All prepainted metal sheets shall be separated from timber by a DPC strip the width of the purlin and fixed to the purlin, with flat-headed galvanised nails. All timber purlins shall be treated with an approved preservative, strength graded and certified to IS 144. All timber purlins shall be at least C16 strength grade.

In exceptional circumstances where the bay width is up to 5.1m, timber purlins 175mm x 75mm at a maximum spacing of 1.4m centres for all single-sheet steel cladding; and 200mm x 75mm at a maximum spacing of 1.0m centres for fibre-cement cladding and double skin insulated cladding shall be used. (Note however that stanchions and rafters shall be installed as specified for a 6.4m bay).

**B.11.2 Steel Purlins** shall be galvanised (minimum galvanised weight 275g/m<sup>2</sup>), sized and installed as per the manufacturer’s instructions. All steel purlins shall be pre-painted in the factory to the same standard as prepainted cladding material and listed on S.102.

**B.11.3 Laminated Timber.** Purlins may be used instead of steel purlins provided a performance guarantee is given by the manufacturer that they are suitable for damp acid environments. They shall be sized and installed according to manufacturer’s instructions for fibre-cement and steel sheeted roofs as appropriate.

**B.11.4 Purlin Cleats** for timber purlins shall be at least 250mm wide and shall extend to a height of at least two thirds the purlin depth. They shall be placed downslope of the purlin and securely fixed to truss/rafter (Figure 5). For steel purlins, cleats shall be fitted as per manufacturers' instructions.

**B.11.5 Side Rails for Cladding** shall be 150mm x 75mm treated timber or preformed steel rail. Where timber is used, a DPC strip shall be fitted between the treated timber and the prepainted cladding sheet. Steel rails shall be sized and fixed in accordance with manufacturers specification and instructions.

**B.11.6 Fixing of Roof and Side Cladding Sheets.** Cladding Sheets shall be handled, stored, cut, laid and fixed in strict accordance with manufacturer's instructions. Sheets shall be laid with overlaps away from the prevailing winds. Where end laps are required the overlap shall be a minimum of 150mm. Steel cladding shall not be cut by angle-grinder, but only by "nibbler".

**B.11.7 Fixing of Spaced Roof Sheeting.** The gap shall not be less than 12mm (30mm gap is recommended for beef and sheep units, 20mm for cow units, and 12mm is recommended over the calf creep area in suckler units). The first two sheets at gable ends shall be overlapped, but all other sheets shall have a space between them. Sheets shall have one fixing per purlin through each of the corrugations forming the edge of the sheet, and no more than two corrugations shall be free of a fixing.

For fibre cement sheeting only: It is permitted for end sheets not to be over lapped, however, in these cases the x-bracing in plane of roof shall be double bolted at junction between rafter and bracing. Also only two nails shall be used per sheet per purlin.

**B.11.8 All fixings shall be corrosion resistant** and shall be suitable for the type of purlin or rail used, as recommended by the manufacturer. Sheets shall be fixed in the recommended manner and with the recommended number of fixings per sheet per purlin/rail. Suitable washers shall be used with each fixing. It is recommended that all fixings are stainless steel.

## B.12 ROOF DRAINAGE

Gutters and Down Pipes shall be fitted complete with necessary brackets and securely fixed. The number of bays drained by a standard 150mm half-round gutter is as follows:-

**Table 15:**

Up-slope length of roof not exceeding	6.0m	8.5m	10m	12m
No. of 4.8m bays drained by gutter with a min. slope of 10mm/bay	8	6	5	4

A 75mm down-pipe is adequate for any of the above combinations, if situated at one end of the gutter run; otherwise a 100mm down-pipe is required. Down-pipes shall be protected against damage. Pipes shall discharge at ground level over a gully trap or preferably through a back inlet type gully trap, to the clean water disposal system. All drainage shall comply with specification S129:- Farmyard Drainage.

It is strongly recommended that all gutters are plastic, particularly in valleys to ensure a long life. Where galvanized steel gutters are used they shall be a minimum of 1.2mm thick.



## B.13 ELECTRICAL INSTALLATIONS

**B.13.1 Wiring and fittings** shall be installed, and all work shall be carried out in accordance with the Fourth Edition of the National Rules for Electrical Installations, ET101:2008 specifically Part 7-705: Requirements for special installations or locations - Agricultural and horticultural premises. An ETCI completion certificate shall be required, signed by the Electrical Contractor(s) or a person duly authorised to act on his/her behalf to certify that the electrical installation has been constructed and/or has been tested according to the National rules of Electrical Installations and has been found to be satisfactory. An associate certificate, specifically for agricultural work, the "Supplementary Agricultural Certification Form" shall also be signed by the Electrical Contractors or authorised persons and the number of the main ETCI completion Certificate clearly marked on it. If no valid numbered ETCI Certificate is available for the completed installation, then the Electrical Contractor shall complete a new numbered ETCI Certificate indicating that the new installation has been tested for safety and compliance, and note that number on the Supplementary Form. The signed printed "Supplementary Agricultural Certification Form" together with a copy of the ETCI Completion Certificate shall be given to the Department before grant-aid can be finally certified.

**B.13.2 Artificial Lighting** shall be provided in all houses. The following lux levels are the minimum for each type of house:-

- 50 lux: Hay barns; Produce Stores.
- 50 lux: All livestock Houses.
- 100 lux: Isolation Units; Calving boxes.
- 200 lux: Dairies; Milking Premises; Cow Byres.

Note: As a guide 5 Watts/m<sup>2</sup> using a florescent tube gives approximately 50 lux.

## B.14 NATURAL LIGHTING

Good use of daylight is important for safe working conditions and for animal health. The minimum number of translucent sheets on each roof slope or single-sided house shall be as follows:-

**Table 16:**

Shed Span up to:	Minimum No. of standard 2.6m translucent sheets per 4.8m run of shed
4.2m	1
7.5m	2
9.9m	3

Only translucent sheets listed on S.102 may be used. Translucent sheets may be omitted where spaced sheeting is used for the entire roof.

**A safety grid shall be installed under every translucent sheet.** The grid shall be as set out in clause B14.1 to B14.5. Alternative proprietary safety grids may be permitted subject to prior acceptance by the Department of Agriculture, Food and the Marine.

**B.14.1 Grid Location.** The safety grid shall be placed underneath the clear light and on top of the supporting purlins. This means that purlins will be able to directly support any weight placed on the grid.

**B.14.2 Grid Size.** The grid shall consist of 16mm diameter steel bars, running for the full length of the clear sheet. The bars shall be spaced at not greater than 150 mm intervals across the width of the clear sheet. Alternatively, 12mm bars may be used at not greater than 125mm spacing.

**B.14.3 Protection of steel.** All bars shall be treated as structural steel in accordance with Clause B.3 of this specification. It is strongly recommended that they be hot-dip galvanised.

**B.14.4 Grid Support.** At the top purlin (highest purlin) the bar shall be bent into a L-shape, with the leg of the L pointing towards the ground so as to prevent the bar from sliding over the purlins. Each bar shall be rigidly secured to each purlin (e.g: using a galvanised metal strap) so that it cannot move from side to side. The fixings shall be corrosion resistant. Each bar of the safety grid must be fixed independently of the clear sheet.

## **B.15 DOORS**

All doors wider than 1.2m shall be sliding. Doors to central passages, where fitted, shall also be sliding. The sliding gear shall be fitted and erected as per manufacturers' instructions for the size and weight of door fitted. It is important that the sliding track is perfectly straight when erected. The sliding track shall comply with EN 1527. A sliding door should preferably incorporate a hinged type outward-opening single personnel door with a minimum head-height of 2.2m above ground level. Cladding materials for doors shall conform, at least, to the standards specified in S102.

It is recommended that all sliding doors be at least 300mm wider than opening and that the flashing over the door is extended for the full length of the door track. Additionally, it is recommended that a gate is used inside a sliding door to an animal area, and that the lower 1.2m of the inside of the door is lined with 12mm WBP plywood.

Steel roller doors are also permitted, and shall be manufactured from cladding material that conforms to the standards specified in S102. All roller doors shall also comply with EN 13241-1

## **B.16 CERTIFICATES**

The following certificates shall be given to the Department before grant-aid will be paid:

- "Concrete" Certificate (Clause B6)
- "Electrical" Certificate (Clause B13)
- Certificate of Protection of Structural Steel
- Certificate of Structural Timber Treatment, where required