

Rubber Fender Detail

Scale 1:100



Typical Lifebuoy Stand

Not To Scale

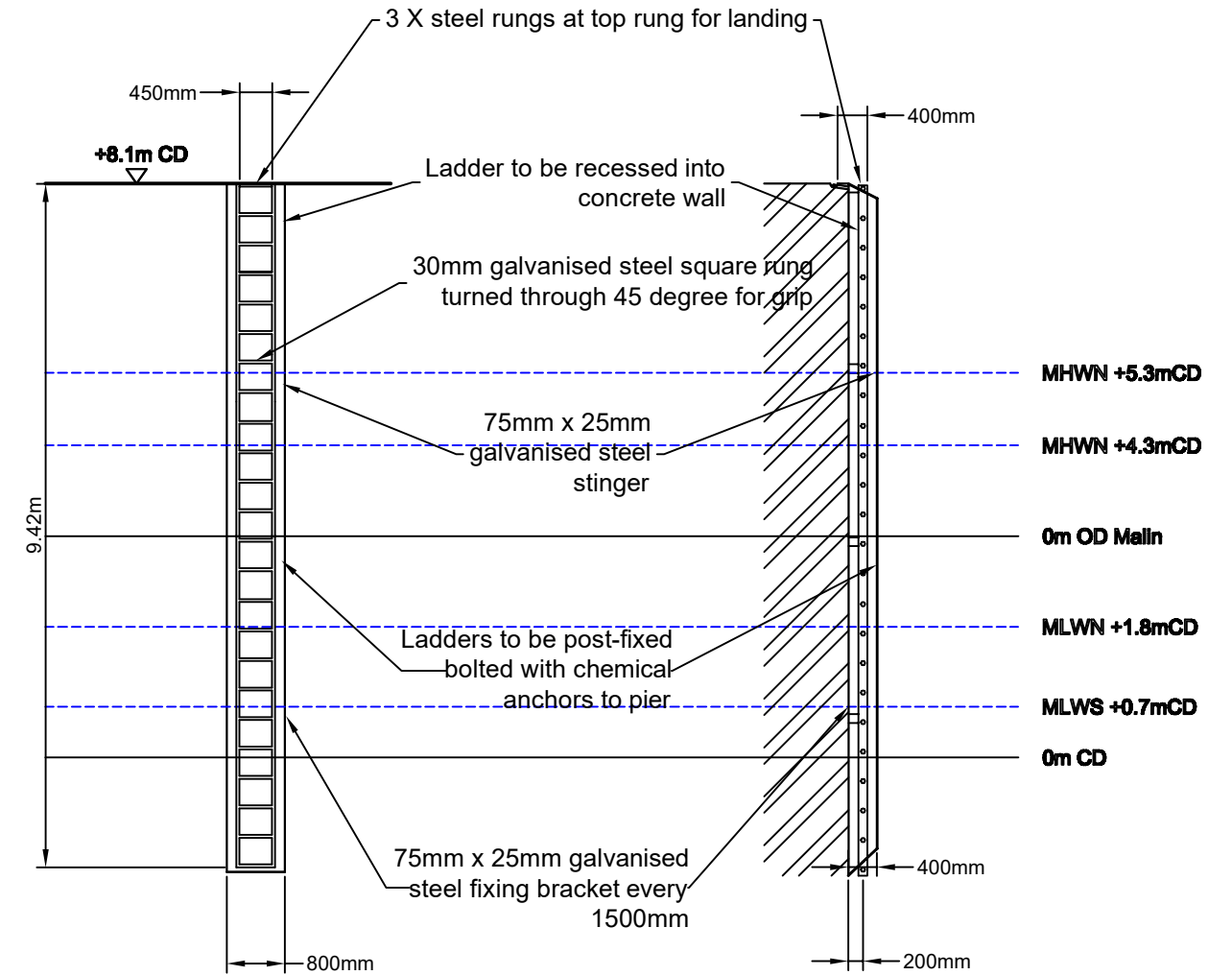

Recessed Ladder Detail

Scale 1:100

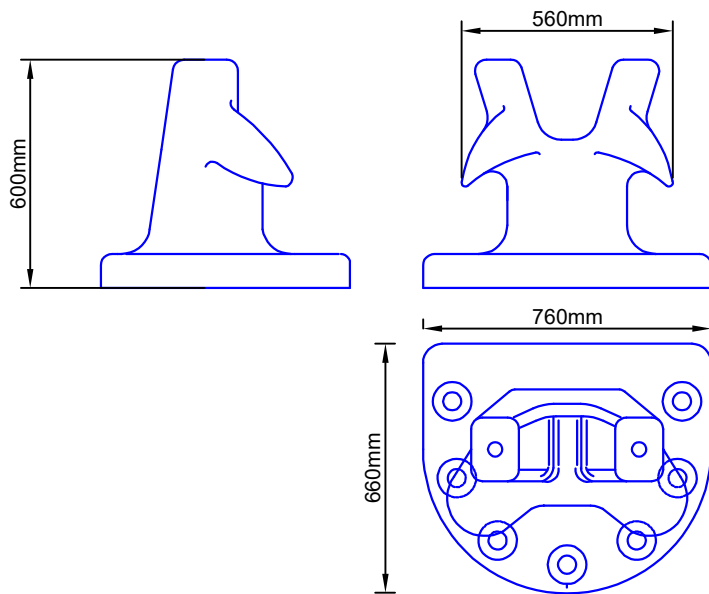

50 Tonne Twin Horn Bollard

Scale 1:20

Cronin Millar
a BYRNE LOOBY company

3 Westbourne Place
Cobh
Co. Cork

Ph: 021 4815441
email: Cobh@ByrneLooby.com
website: www.ByrneLooby.com

This drawing to be read in conjunction with all other CMCE drawings and any other relevant information.

No dimensions are to be scaled from this drawing.

Unless noted otherwise, all dimensions are in millimeters and all levels are in meters from the noted datum.

Copyright reserved.

| Rev: | Description: | Date: | Drawn: | Checked: |
|------|-------------------------------|------------|--------|----------|
| 01 | Revised Foreshore Application | 25/08/2017 | PM | SMC |
| 00 | Foreshore Application | 30/06/2017 | PM | SMC |

| | |
|-----------------|-------------------|
| Client: | Greenore Port Ltd |
| Project: | Greenore Berth 2 |

| | | | |
|------------------|----------------|--------------------|----------------------|
| Title: | Quay Furniture | | |
| Scale: | Varies | Sheet Size: | A3 |
| Drawn By: | PM | Checked By: | SMC |
| Date: | 30/06/2017 | Drawing No: | CM983_MA_0510_DWG_01 |